

Onshape 101 – 3D Printed Keyfob

Part1: Creating a 3D model

Free subscription only allows public data. Try Onshape Professional to create, edit and share private data with your team. [Try Professional](#)

- Create
- Document...
- Folder...
- Import files...
- Import from
- Label...

Create a new document

My Onshape

Last opened by me

Name	Modified	Modified by	Owned by
Folders			
COIN SAFE	9:14 AM Jan 25	me	me
Documents			
Keyfobbery <small>🌐 Main</small>	11:26 AM Today	me	me
revolve <small>🌐 Main</small>	2:53 PM Yesterday	me	me

Subscription: Free

[Try Professional](#)

[Upgrade](#)

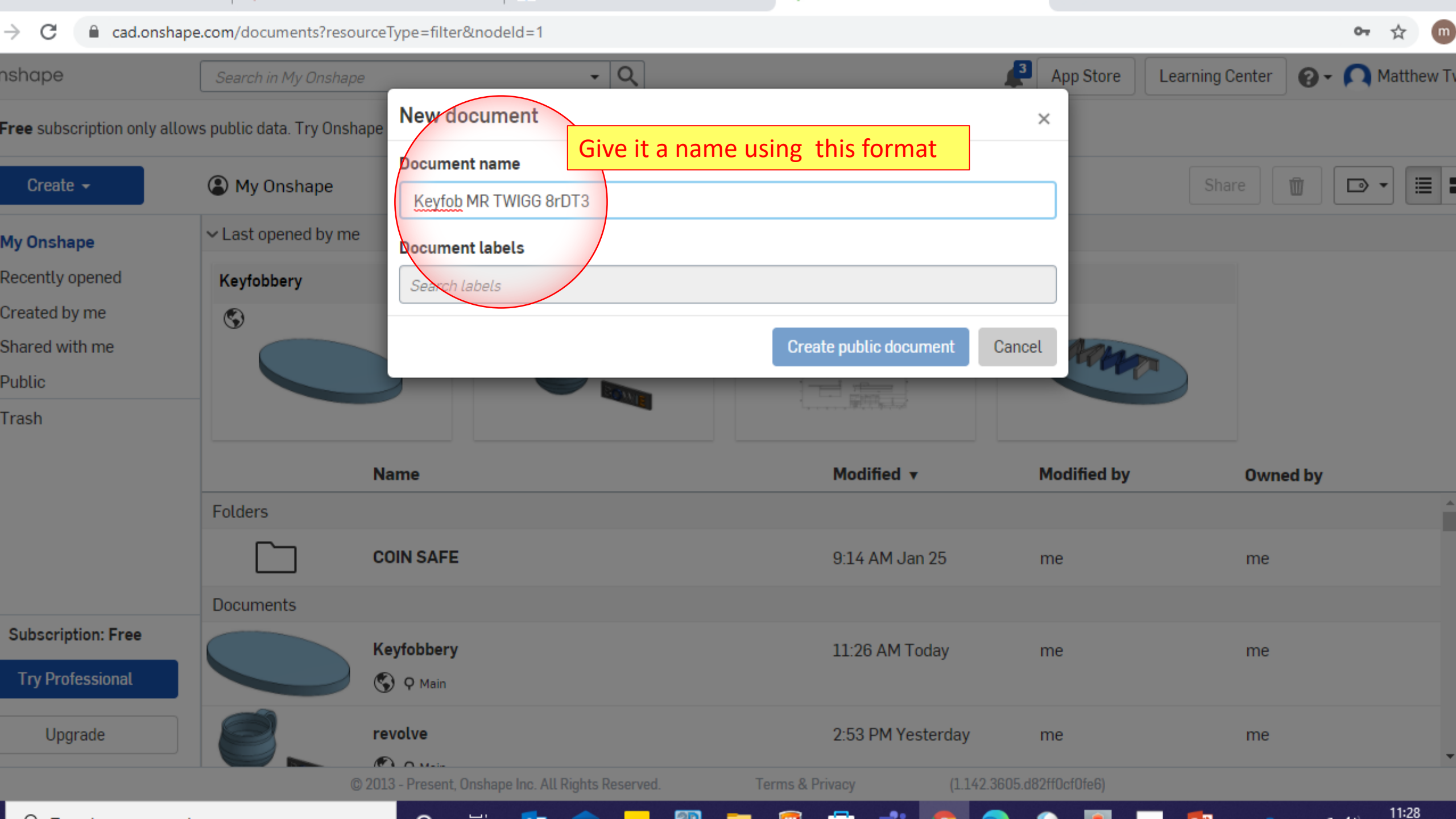

New document



Document name

Keyfob MR TWIGG 8rDT3

Give it a name using this format

Document labels

Search labels

Create public document

Cancel

	Name	Modified	Modified by	Owned by
Folders				
	COIN SAFE	9:14 AM Jan 25	me	me
Documents				
	Keyfobbery Main	11:26 AM Today	me	me
	revolve Main	2:53 PM Yesterday	me	me

Keyframe **Create a NEW SKETCH**



new sketch (Shift-s)
This is the basis for all parts. Select a plane, planar face, or mate
tor on which to create a new sketch.

- Default geometry
 - Origin
 - Top
 - Front
 - Right

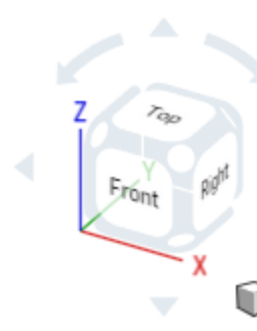
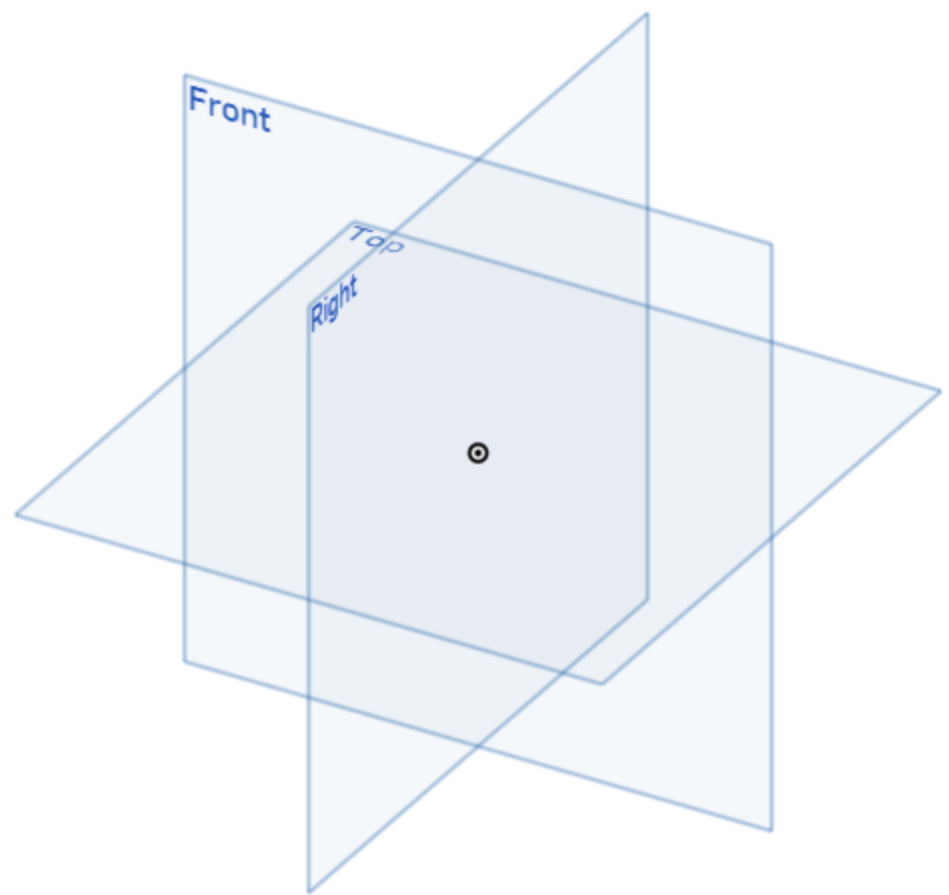

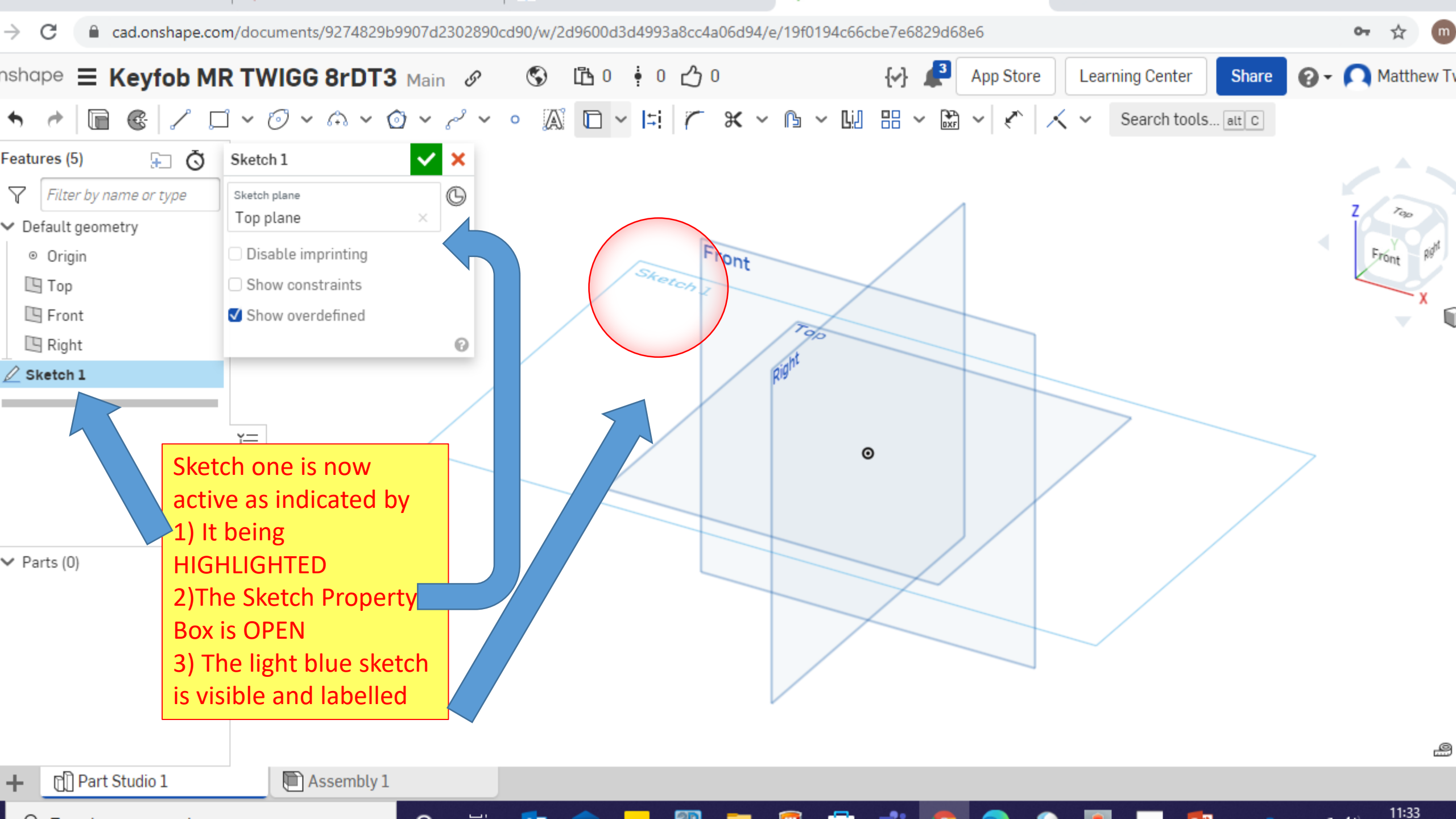

Sketch one is now active as indicated by
1) It being HIGHLIGHTED
2) The Sketch Property Box is OPEN
3) The light blue sketch is visible and labelled

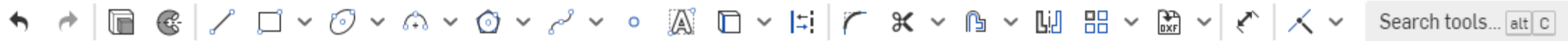

Features (5)

Filter by name or type

Default geometry

- Origin
- Top
- Front
- Right

Sketch 1

Parts (0)

Sketch 1

Sketch plane

Top plane

Disable imprinting

Show constraints

Show overdefined

Click on the View Cube TOP to see the Top Plane full screen

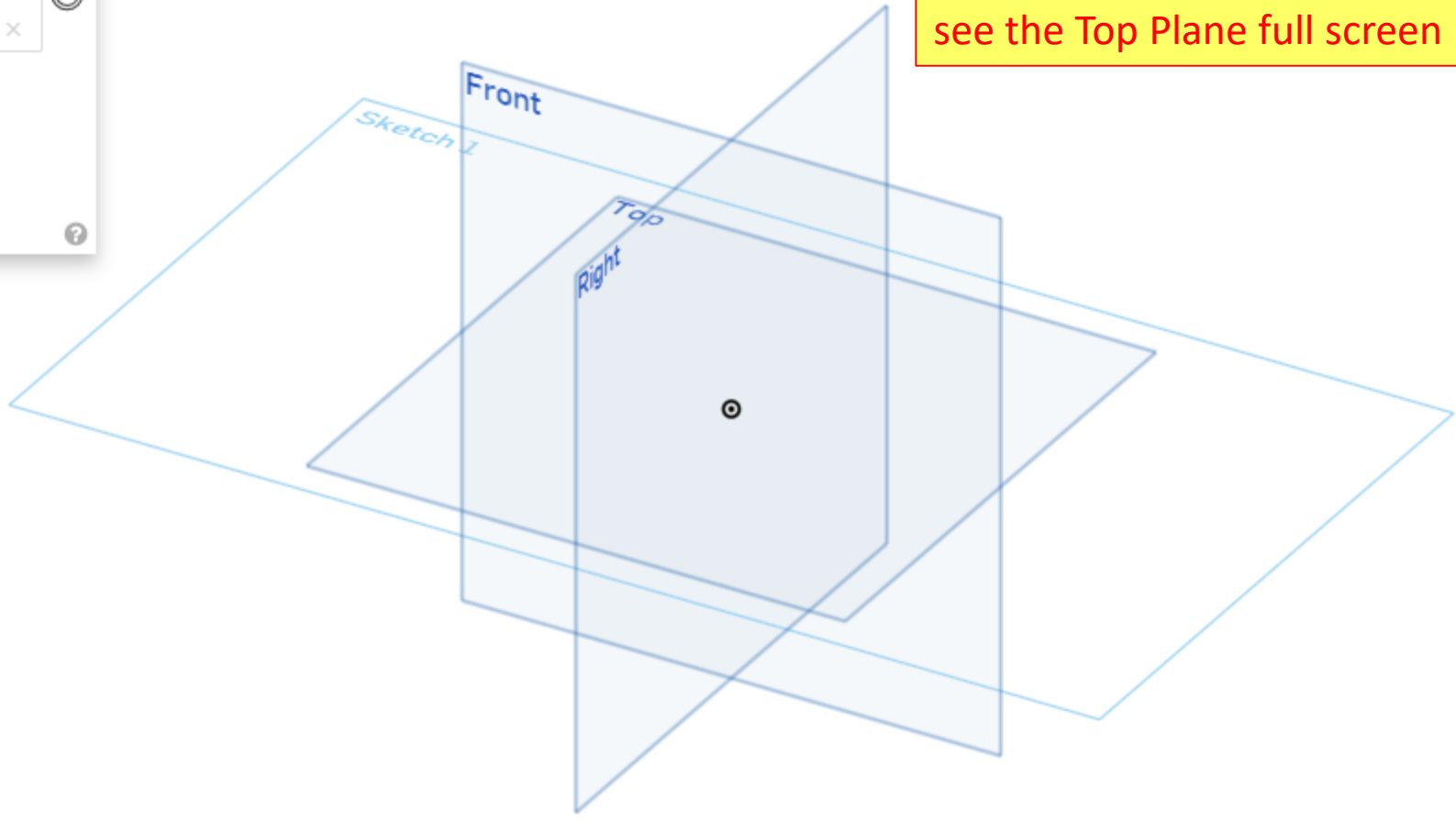
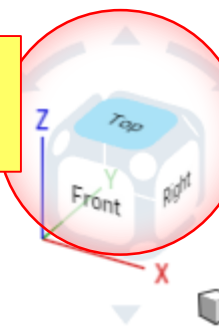

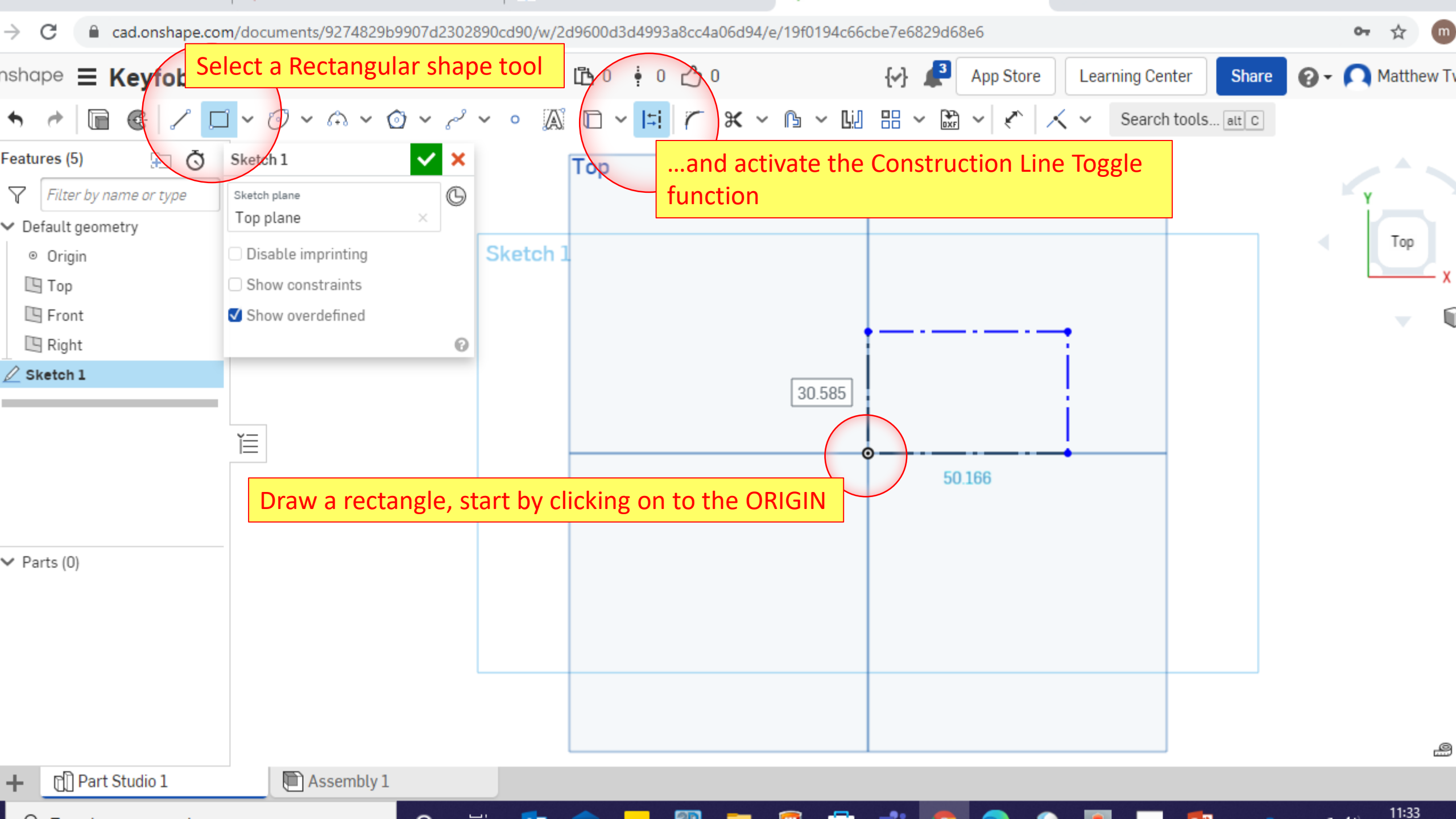

Select a Rectangular shape tool

...and activate the Construction Line Toggle function

Draw a rectangle, start by clicking on to the ORIGIN

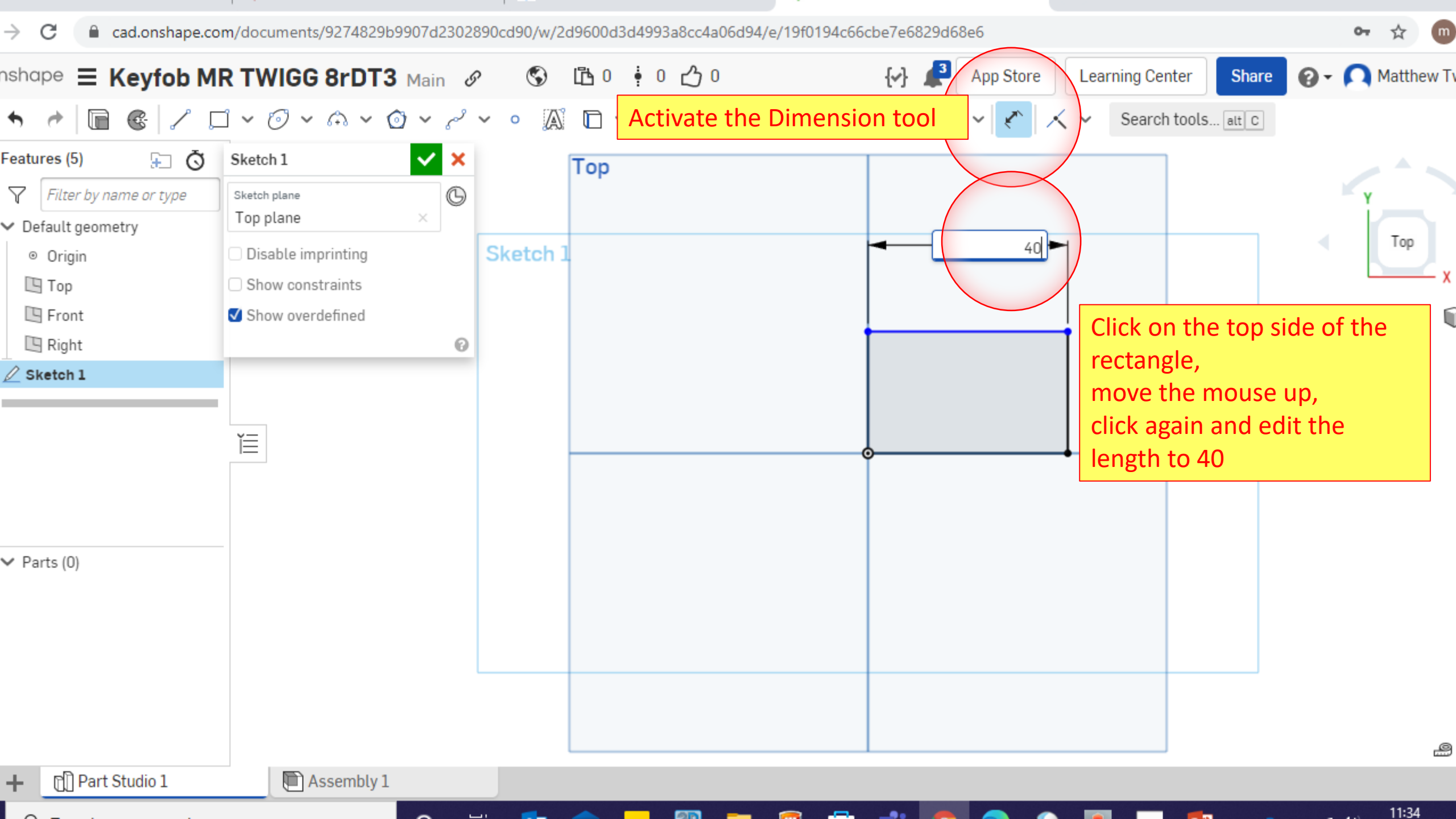

Activate the Dimension tool

Click on the top side of the rectangle, move the mouse up, click again and edit the length to 40



Features (5)

Filter by name or type

Default geometry

- Origin
- Top
- Front
- Right

Sketch 1

Parts (0)

Sketch 1

Sketch plane
Top plane

Disable imprinting

Show constraints

Show overdefined

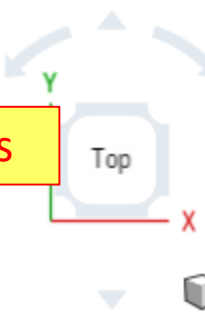
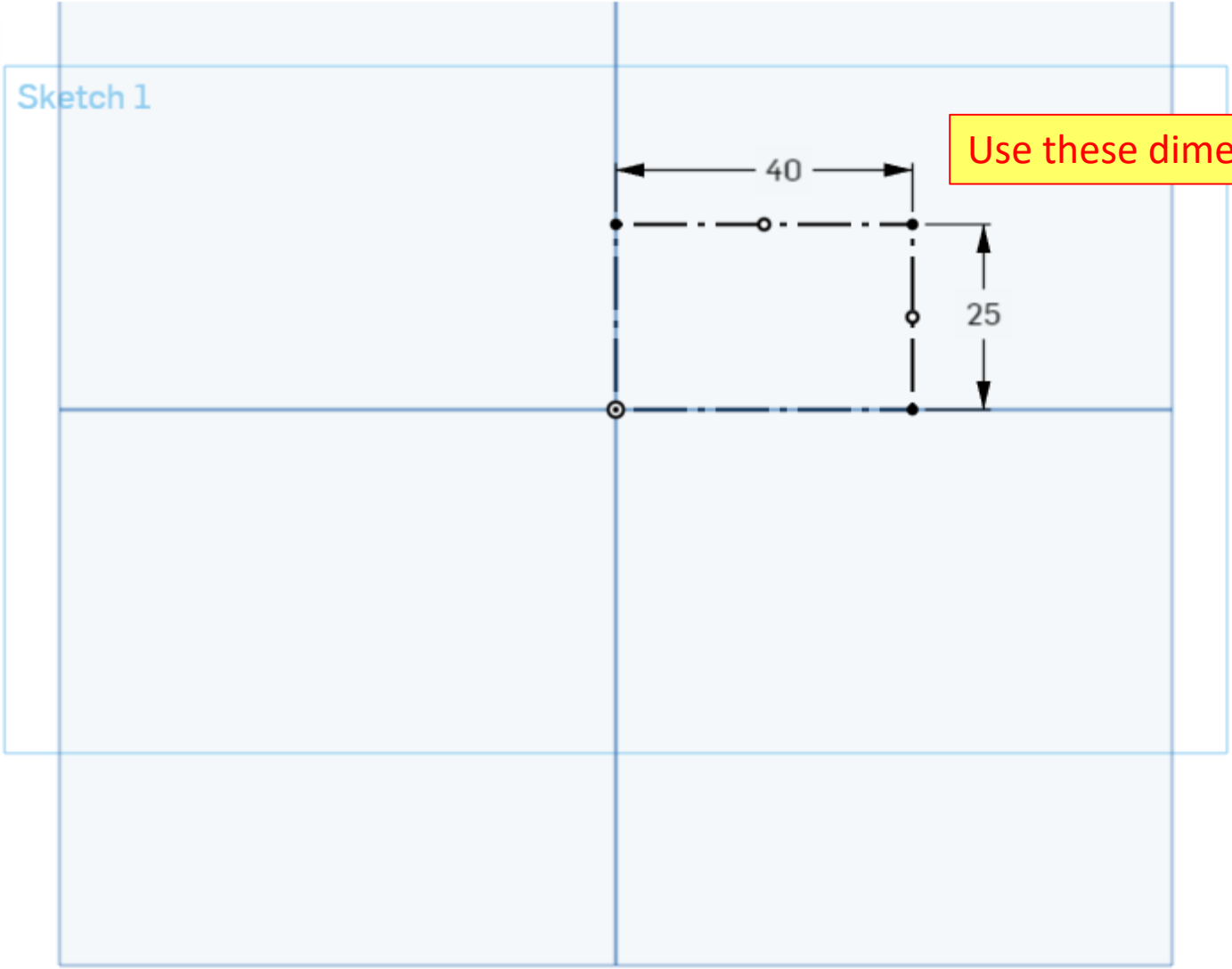

From the CIRCLE tool open the drop down menu
Select and activate the ELLIPSE tool

Features (5)

Filter by name or type

Default geometry

- Origin
- Top
- Front
- Right

Sketch 1

Sketch 1

Sketch plane
Top plane

Disable imprinting

Show constraints

Show overdefined

DO NOT CLICK ANYTHING YET!
Hover the mouse pointer over
the centre of the top side until
a helpful little yellow square
appears....



Features (5)

Filter by name or type

Default geometry

- Origin
- Top
- Front
- Right

Sketch 1

Parts (0)

Sketch 1

Sketch plane
Top plane

Disable imprinting

Show constraints

Show overdefined

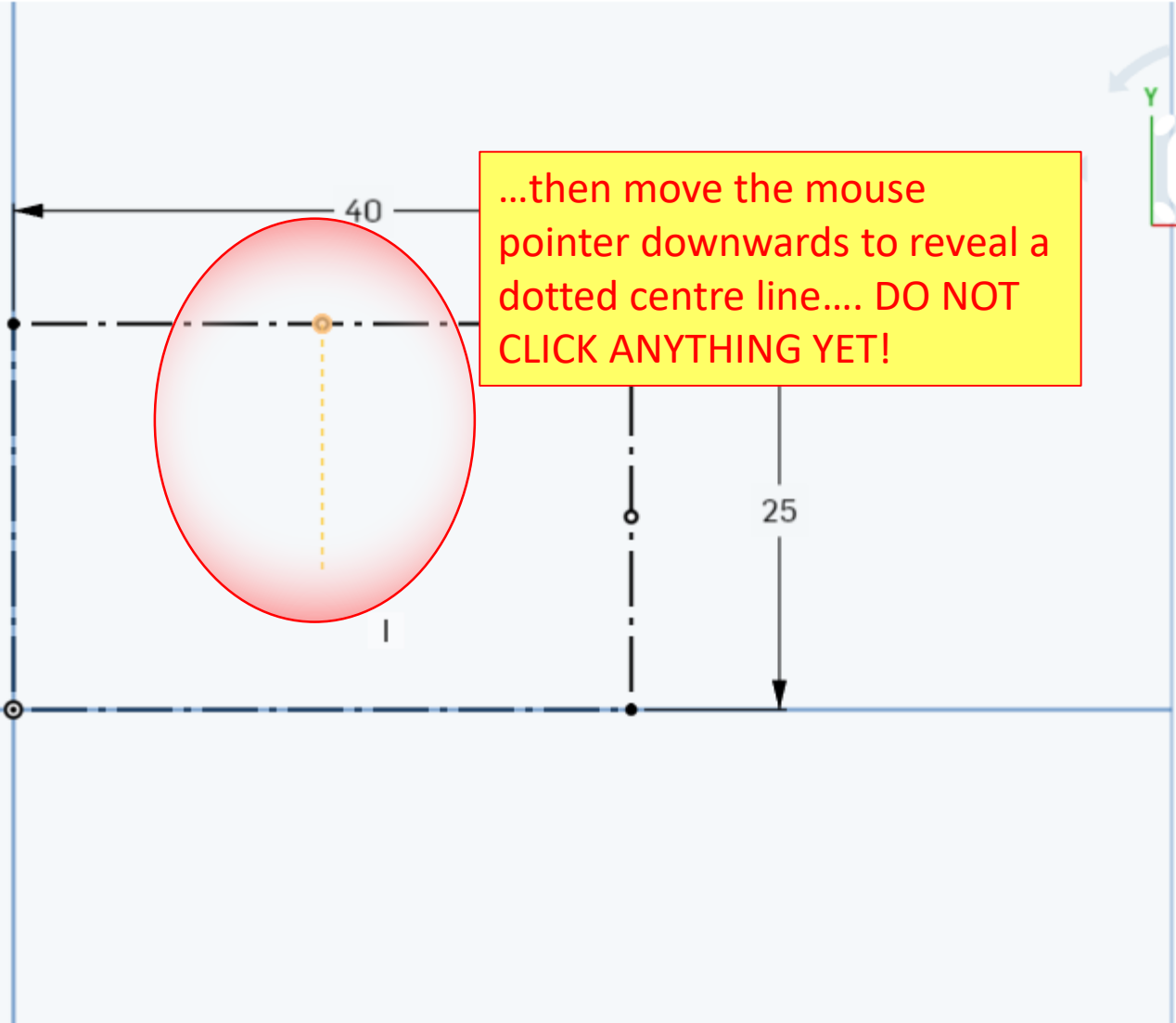

...then move the mouse pointer downwards to reveal a dotted centre line.... DO NOT CLICK ANYTHING YET!



Features (5)

Filter by name or type

Default geometry

- Origin
- Top
- Front
- Right

Sketch 1

Parts (0)

Sketch 1

Sketch plane
Top plane

Disable imprinting

Show constraints

Show overdefined

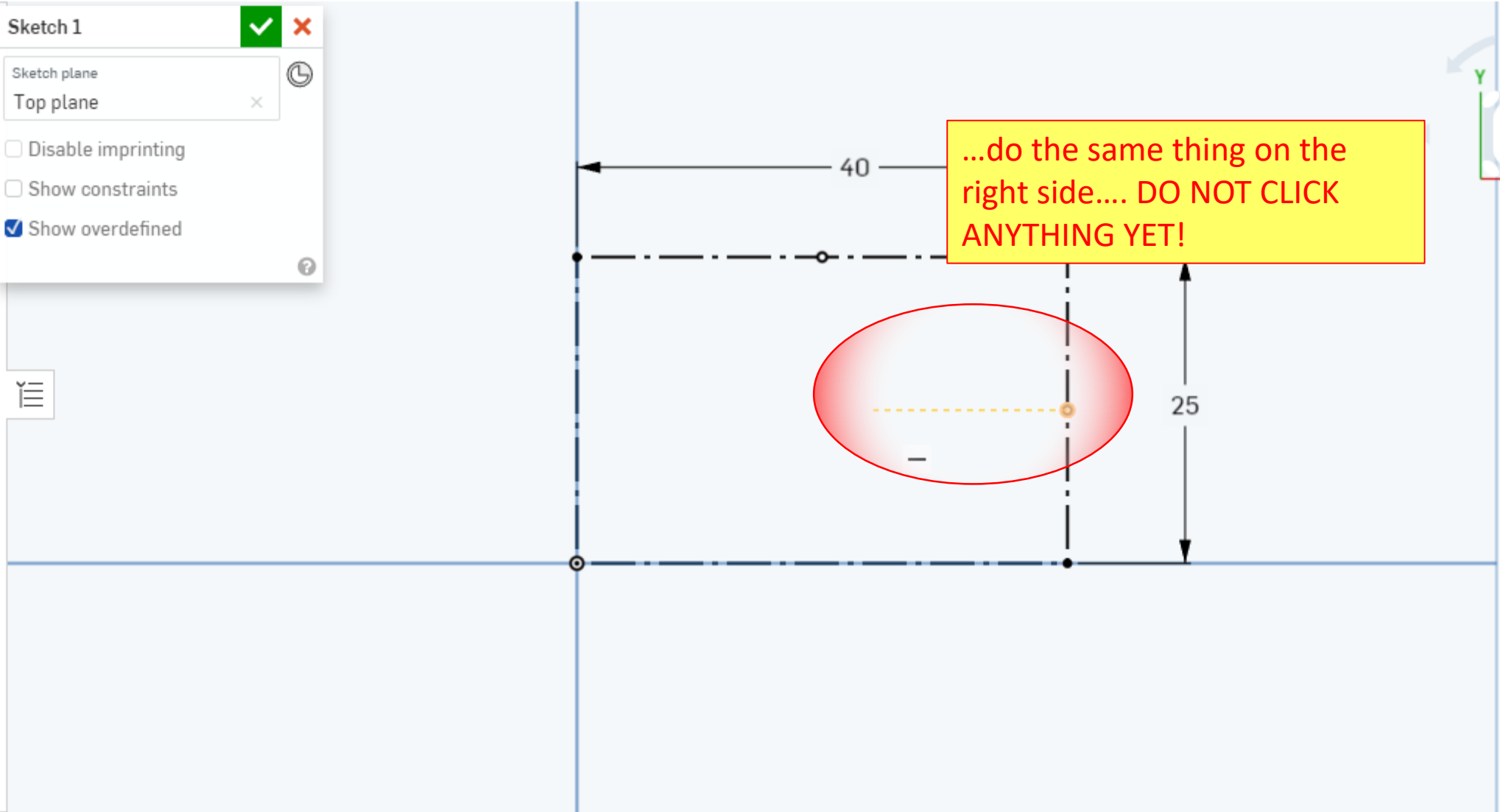

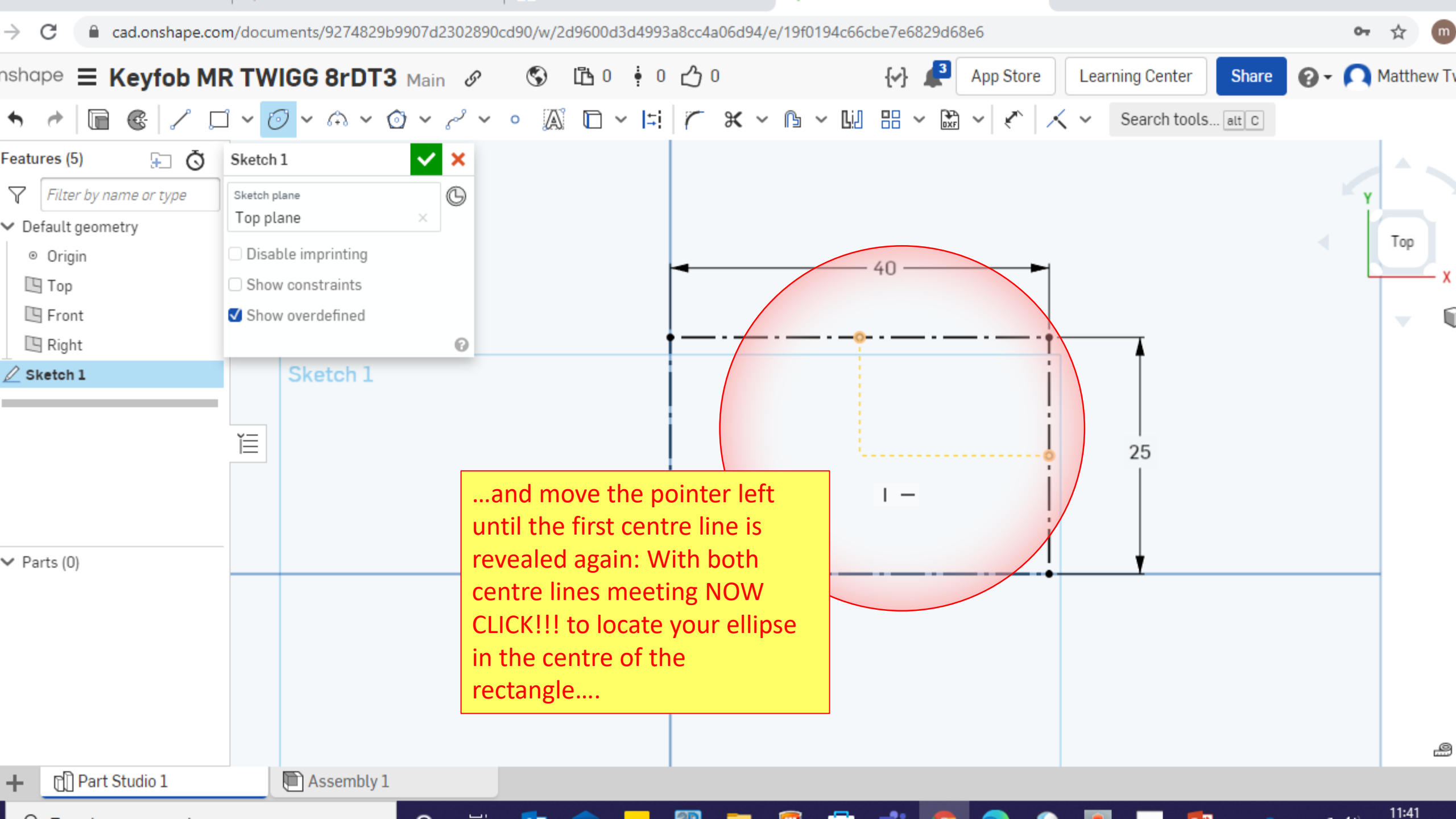

...and move the pointer left until the first centre line is revealed again: With both centre lines meeting NOW CLICK!!! to locate your ellipse in the centre of the rectangle....



Features (5)

Filter by name or type

Default geometry

- Origin
- Top
- Front
- Right

Sketch 1

Parts (0)

Sketch 1

Sketch plane: Top plane

Disable imprinting

Show constraints

Show overdefined

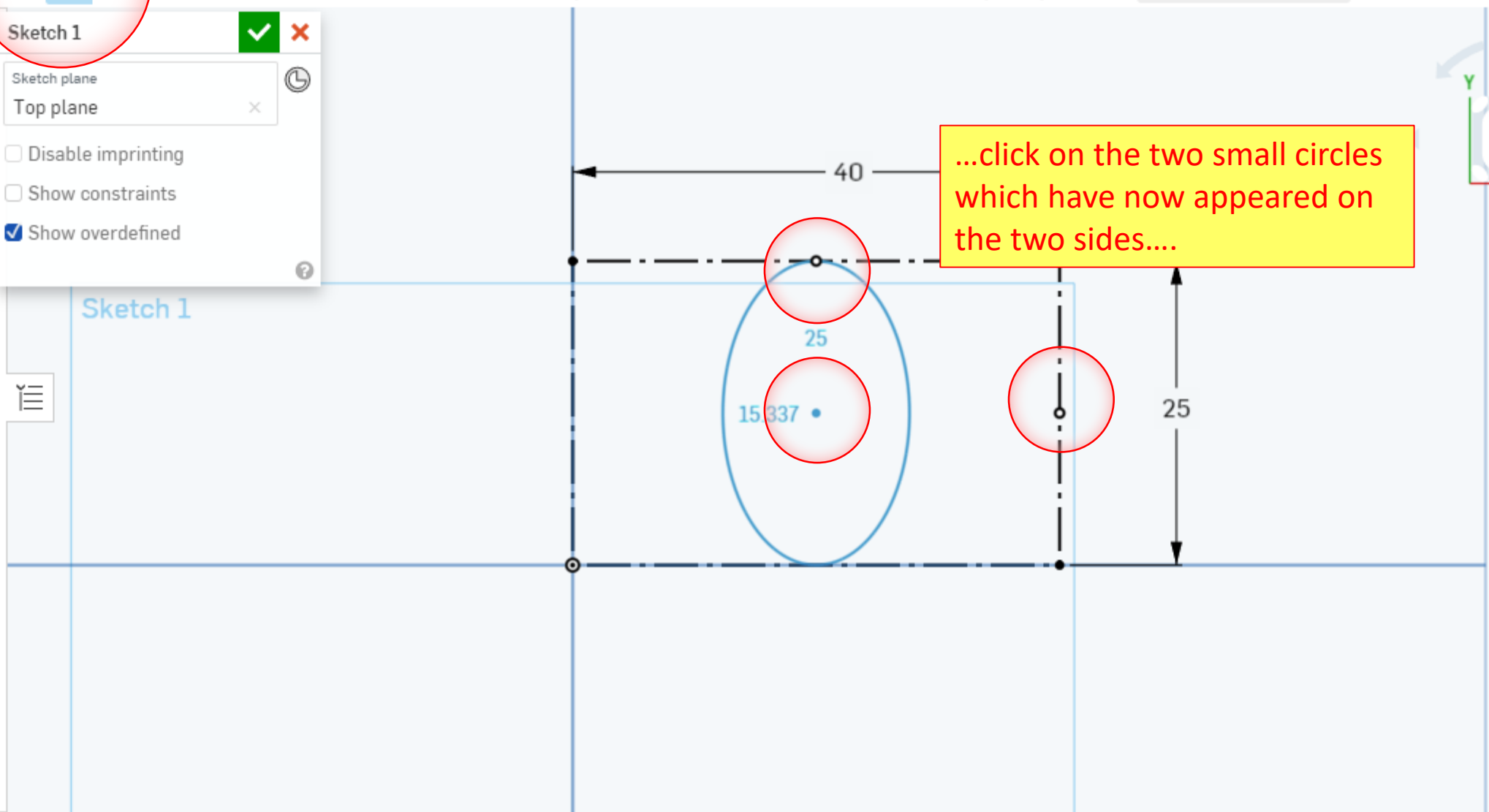

...click on the two small circles which have now appeared on the two sides....



Features (5)

Filter by name or type

Default geometry

- Origin
- Top
- Front
- Right

Sketch 1

Parts (0)

Sketch 1

Sketch plane
Top plane

Disable imprinting

Show constraints

Show overdefined

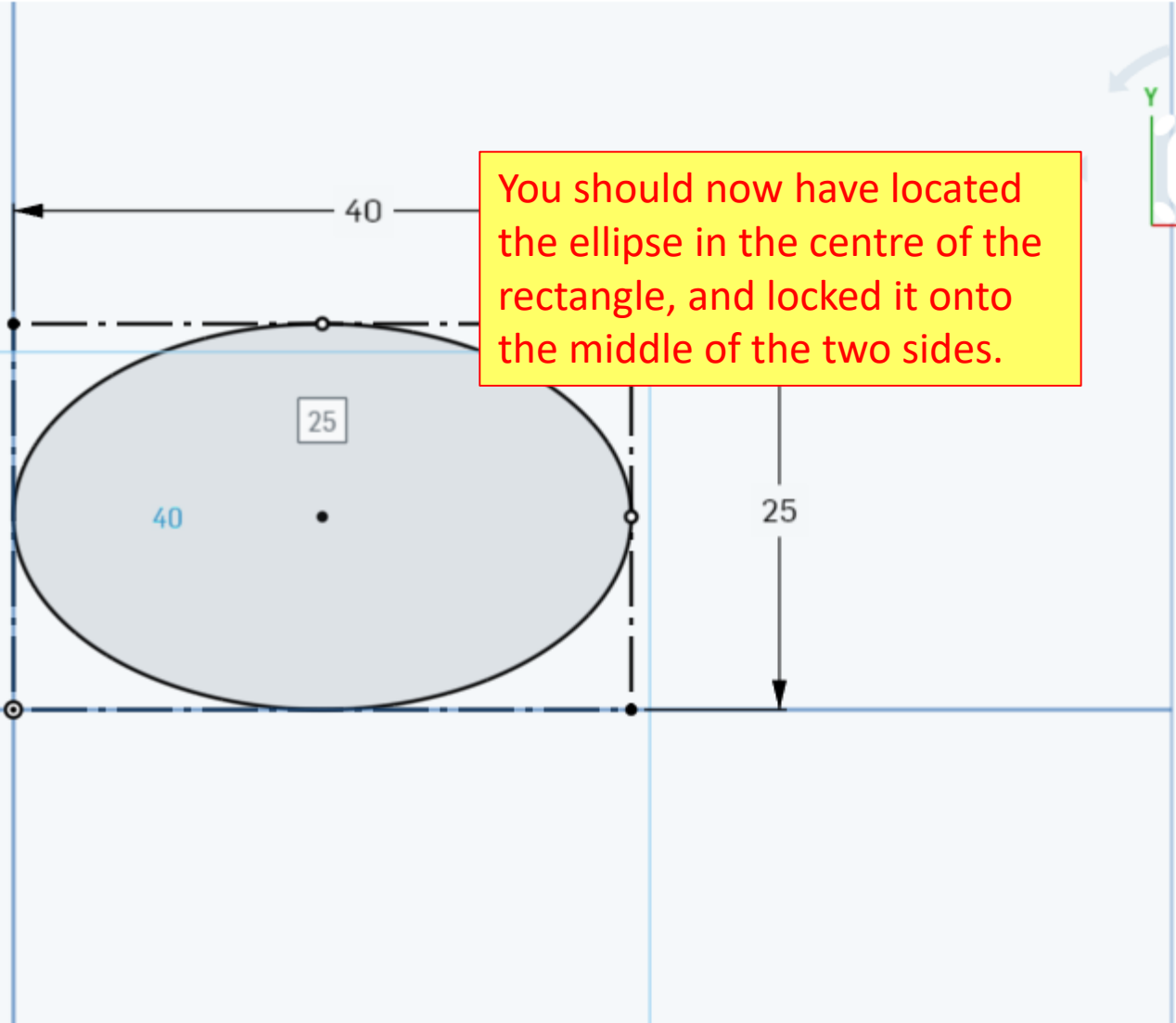

You should now have located the ellipse in the centre of the rectangle, and locked it onto the middle of the two sides.

With the sketch still active activate the extrusion tool

Features (6)

Filter by name or type

Default geometry

- Origin
- Top
- Front
- Right

Sketch 1

Extrude 1

Extrude 1 ✓ ✕

Solid Surface

New Add Remove Intersect

Faces and sketch regions to extrude

Faces of Sketch 1 ✕

Blind ↙

Depth 25 mm

Symmetric

Draft

Second end position

Click on this arrow to reverse the direction of extrusion

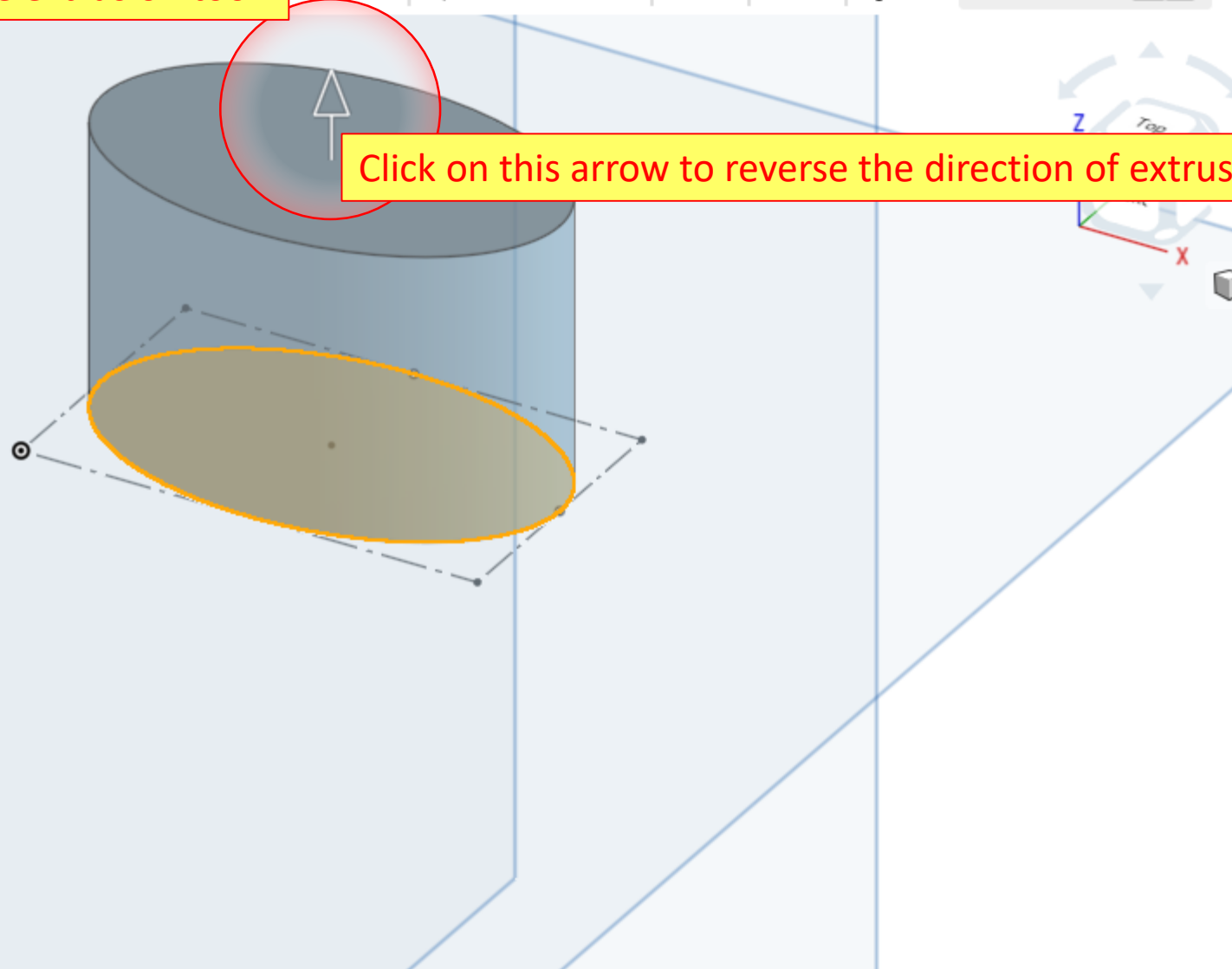

Features (6)

Filter by name or type

Default geometry

- Origin
- Top
- Front
- Right
- Sketch 1
- Extrude 1

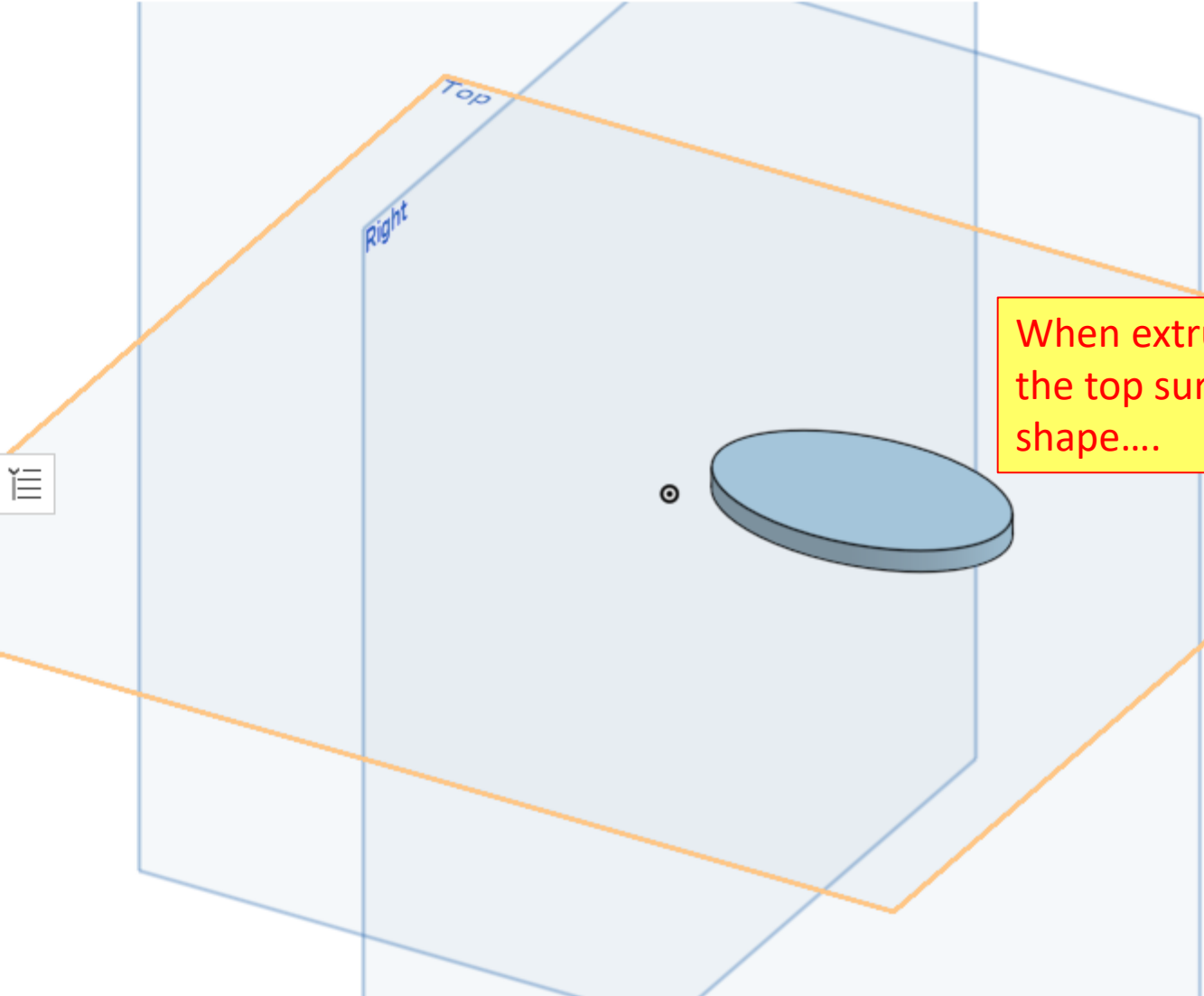

When extruded click to select the top surface of the ellipse shape....

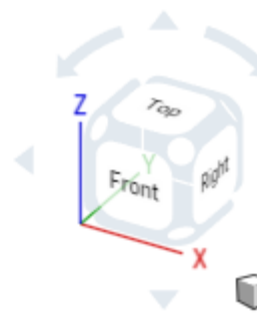

Activate a new sketch on top of the selected surface of the ellipse

Sketch

Features (6)

Filter by name or type

Default geometry

- Origin
- Top
- Front
- Right
- Sketch 1
- Extrude 1

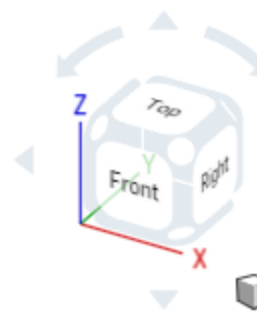
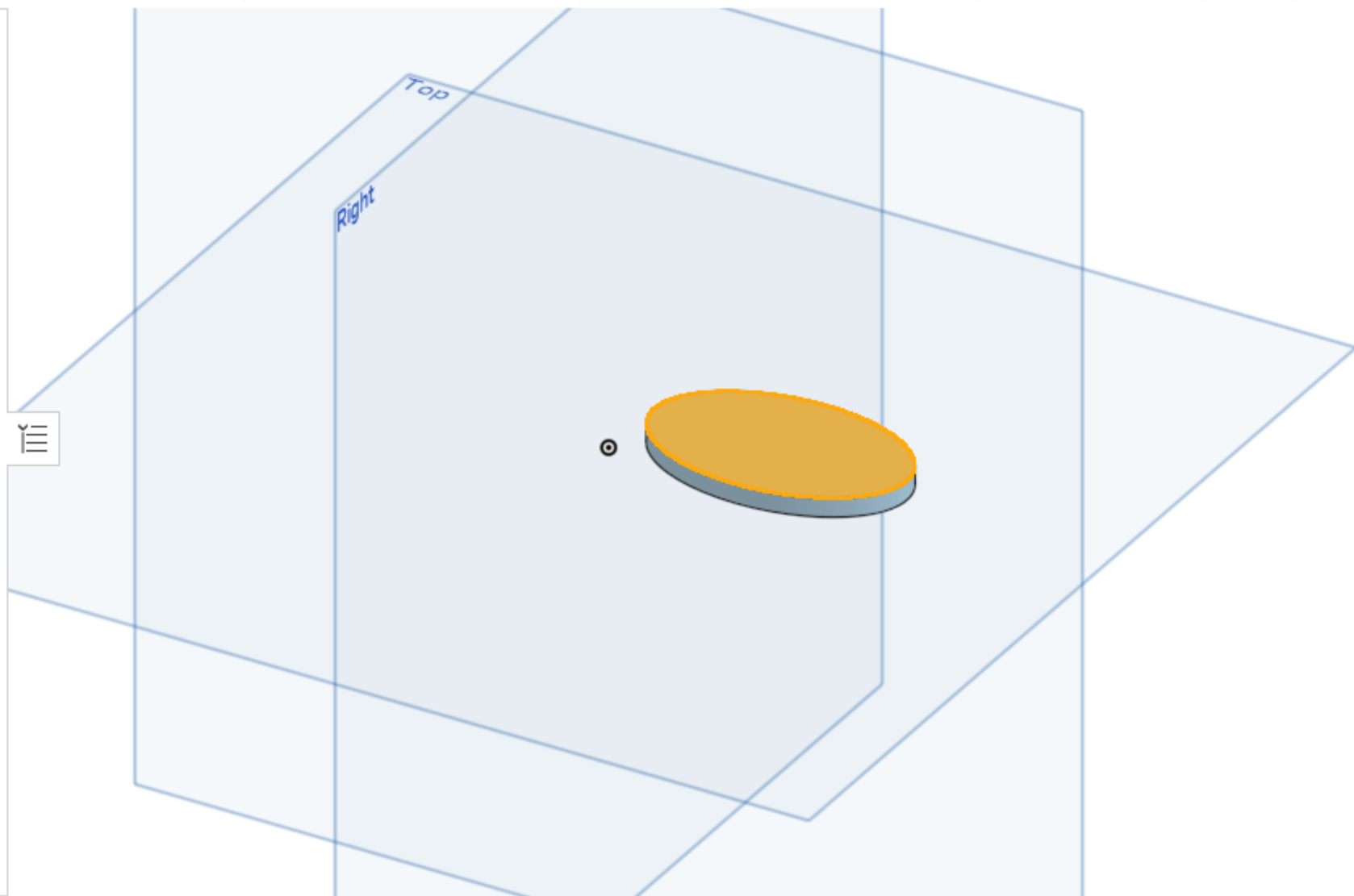

Parts (1)

- Part 1

Area: 785.398 mm²

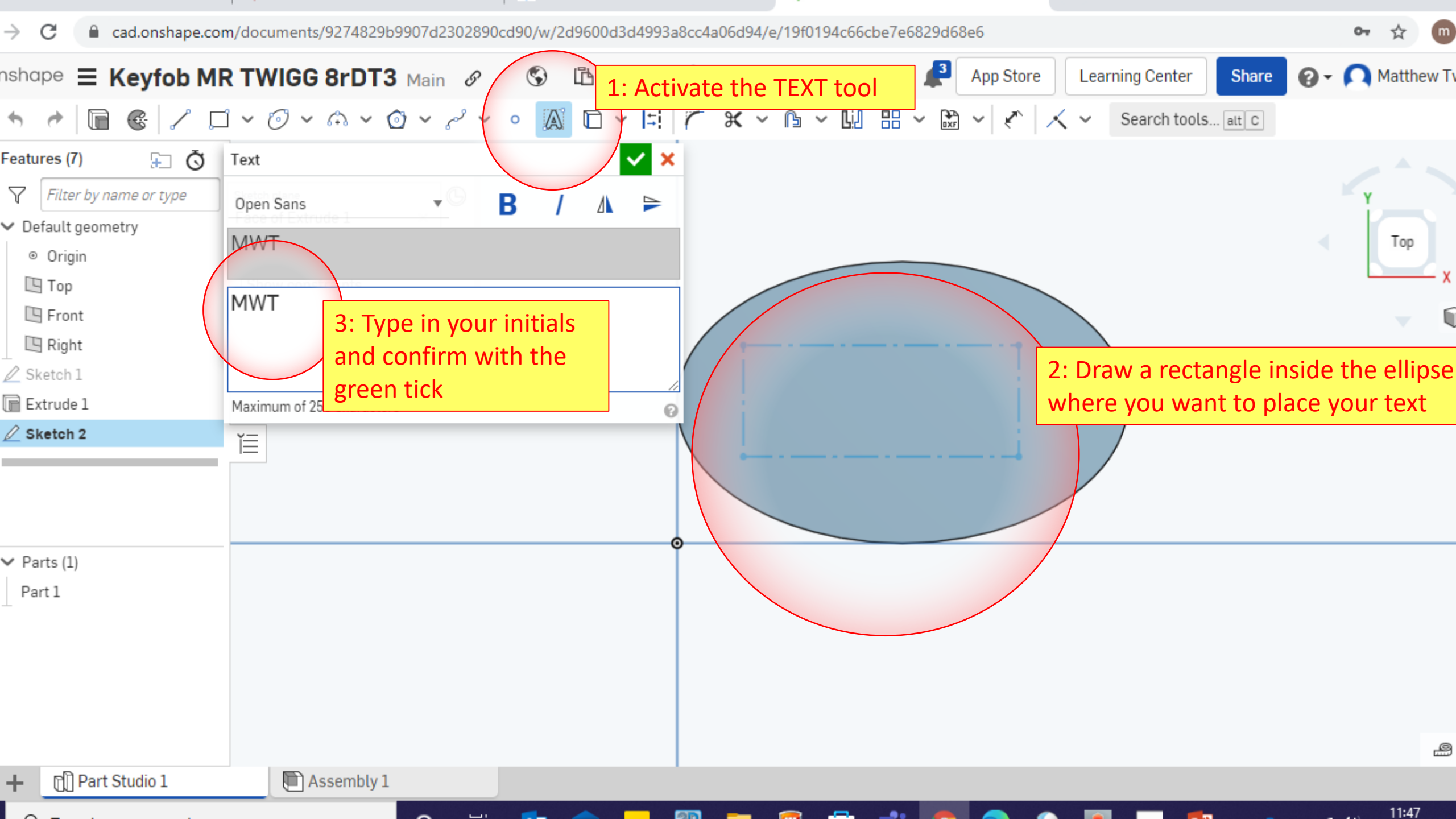

1: Activate the TEXT tool

3: Type in your initials and confirm with the green tick

2: Draw a rectangle inside the ellipse where you want to place your text



Features (7)

Filter by name or type

Default geometry

- Origin
- Top
- Front
- Right
- Sketch 1
- Extrude 1
- Sketch 2**

Parts (1)

- Part 1

Sketch 2 ✓ ✕

Sketch plane

Face of Extrude 1 ✕

Disable imprinting

Show constraints

Show overdefined

Sketch 2

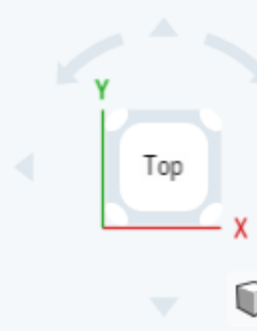
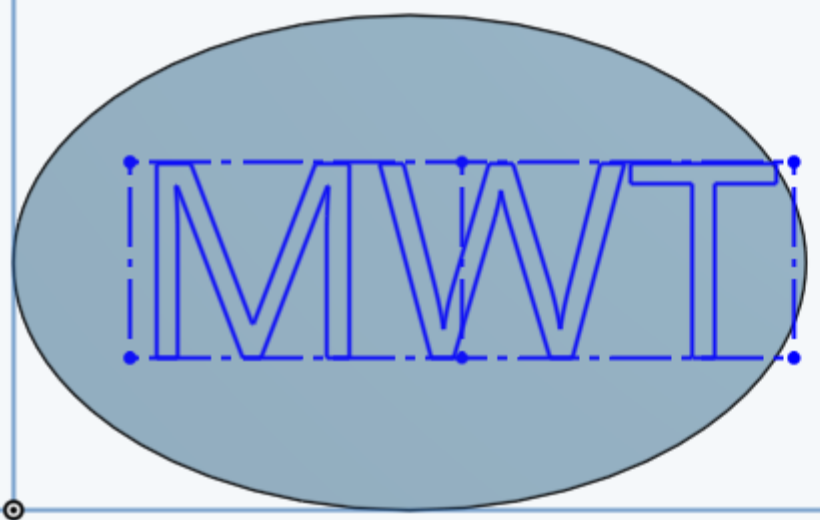

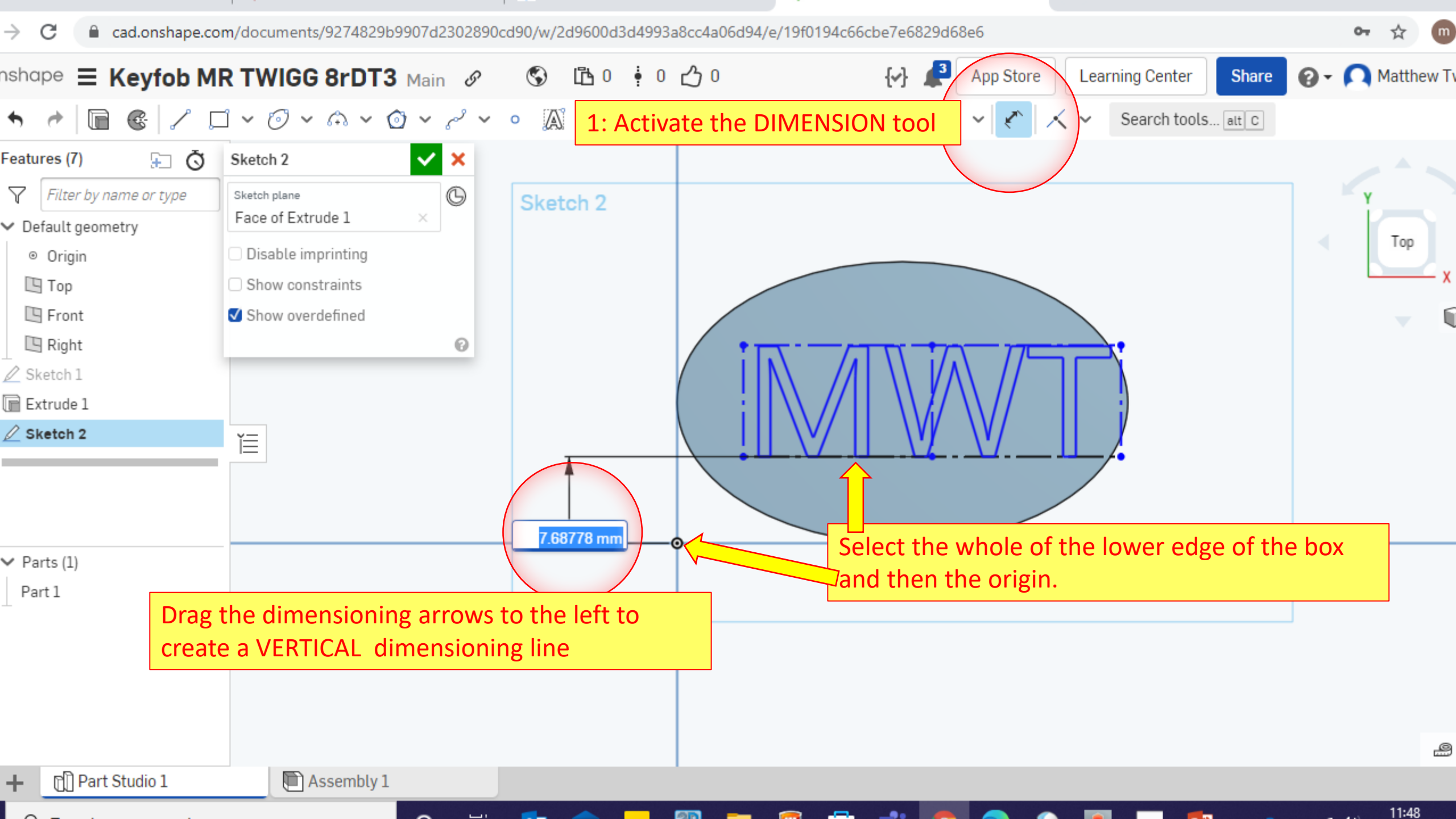

1: Activate the DIMENSION tool

Select the whole of the lower edge of the box and then the origin.

Drag the dimensioning arrows to the left to create a VERTICAL dimensioning line

7.68778 mm

Features (7)

Filter by name or type

Default geometry

- Origin
- Top
- Front
- Right
- Sketch 1
- Extrude 1
- Sketch 2**

Parts (1)

- Part 1

Sketch 2

Sketch plane
Face of Extrude 1

Disable imprinting

Select the whole of the left hand side of the box and then the origin.

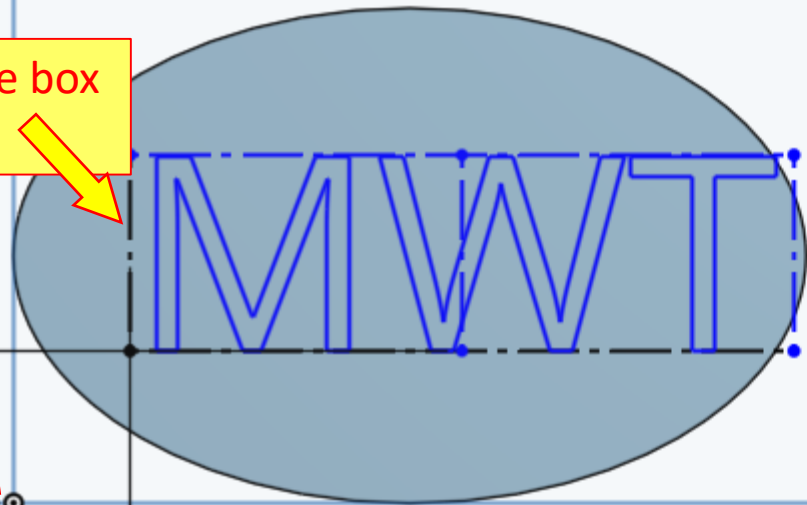

7.688

5.8775 mm

Features (7)

Filter by name or type

Default geometry

- Origin
- Top
- Front
- Right
- Sketch 1
- Extrude 1
- Sketch 2**

Parts (1)

- Part 1

Sketch 2

Sketch plane

Face of Extrude 1

- Disable imprinting
- Show constraints
- Show overdefined

Dimension the top edge of the text box – make it 25mm

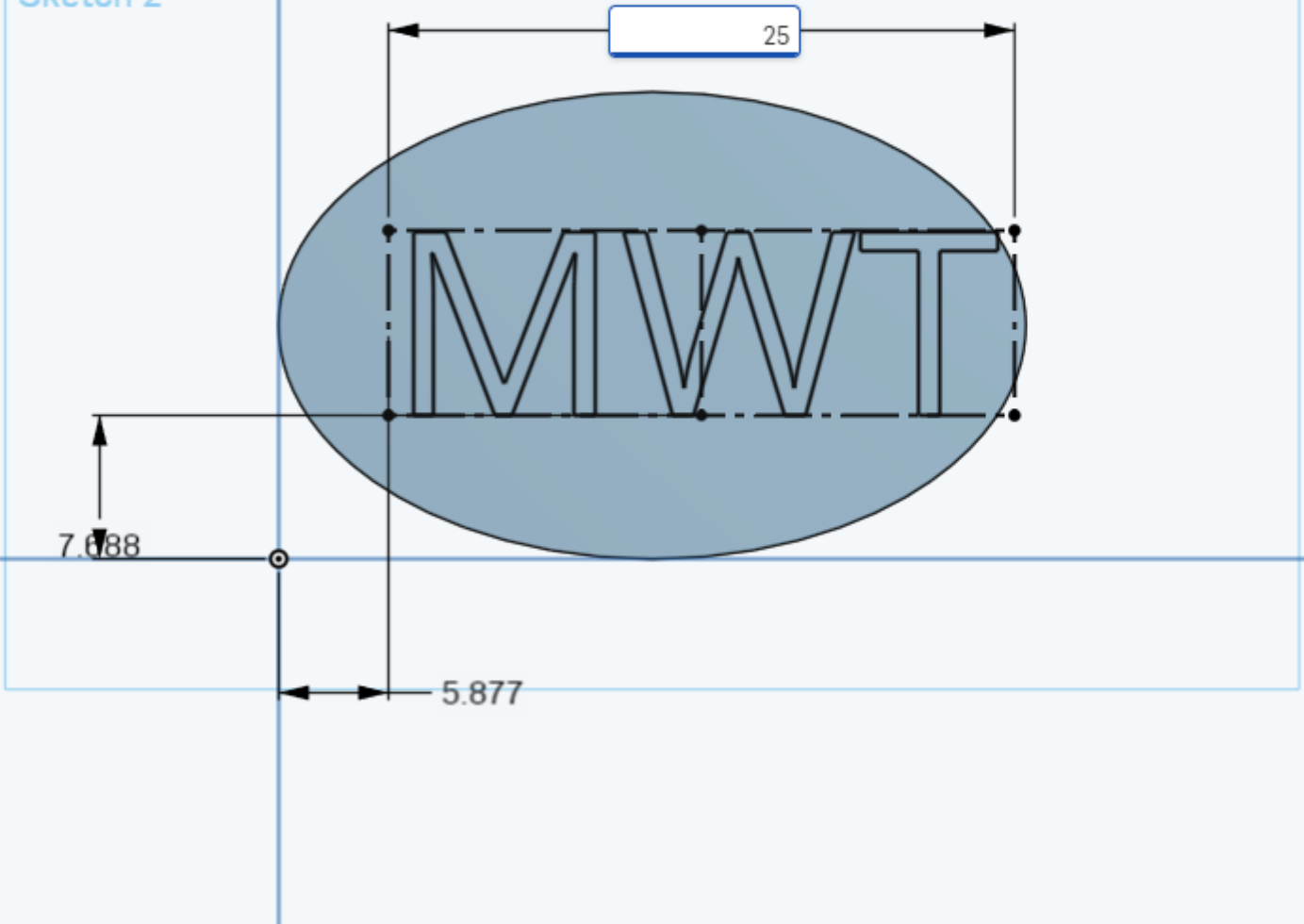

Features (7)

Filter by name or type

Default geometry

- Origin
- Top
- Front
- Right
- Sketch 1
- Extrude 1
- Sketch 2**

Parts (1)

- Part 1

Sketch 2

Sketch plane
Face of Extrude 1

Disable imprinting

Show constraints

Show overdefined

Sketch 2

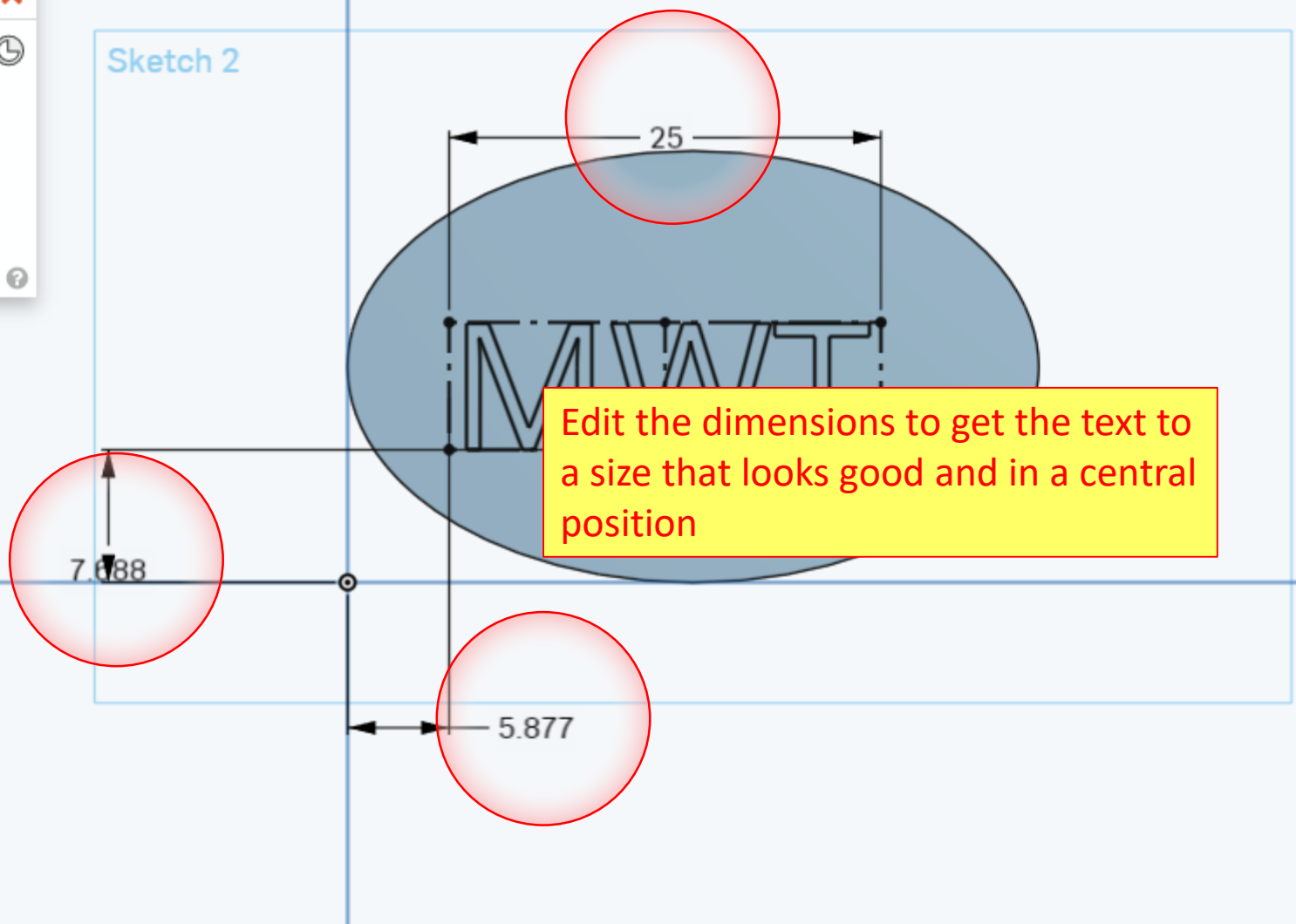

Top

New sketch (Shift-s) ✓ ✗

This is the basis for all parts. Select a plane, planar face, or mate
tor on which to create a new sketch.

Default geometry

- Origin
- Top
- Front
- Right
- Sketch 1
- Extrude 1
- Sketch 2
- Extrude 2**

New **Add** Remove Intersect

Faces and sketch regions to extrude
Faces of Sketch 2 ✗

Blind ▼ ↔

Depth

Symmetric

Draft

Second end position

Merge with all

Merge scope
Part 1 ✗

Parts (1)
Part 1

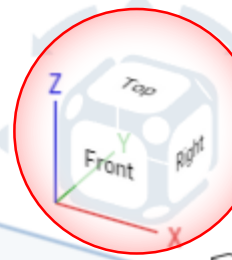
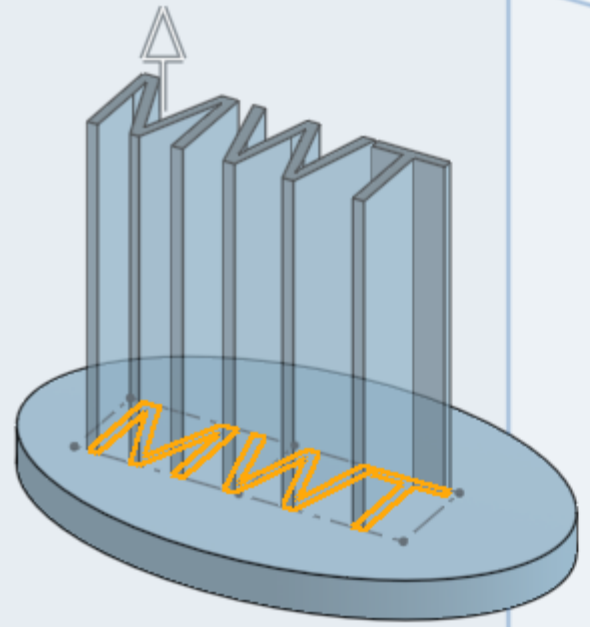

Features (8)

Filter by name or type

Default geometry

- Origin
- Top
- Front
- Right
- Sketch 1**
- Extrude 1
- Sketch 2
- Extrude 2

Sketch 1

Sketch plane
Top plane

Disable imprinting

Show constraints

Show overdefined

Double click on Sketch 1 to RE-Activate it

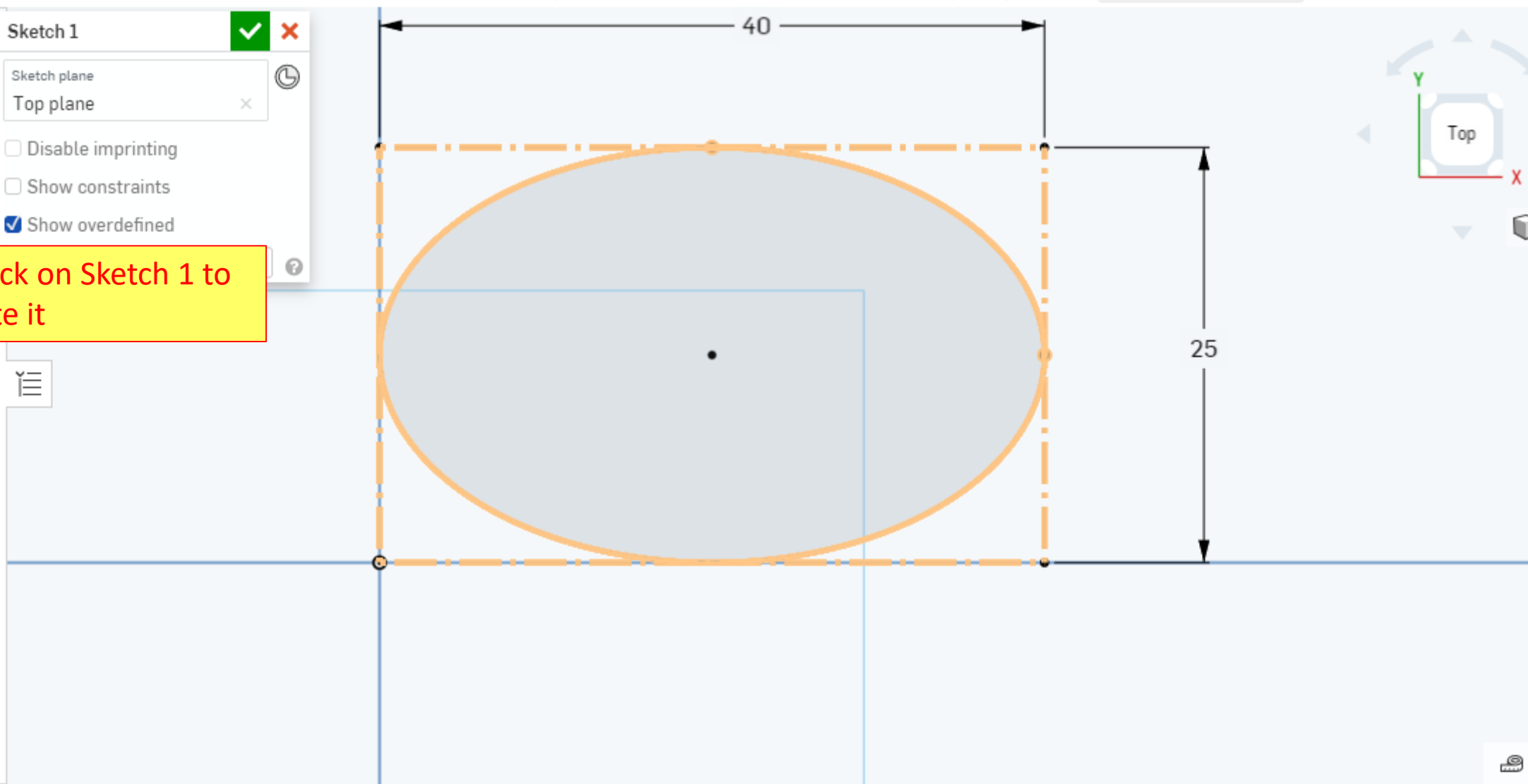

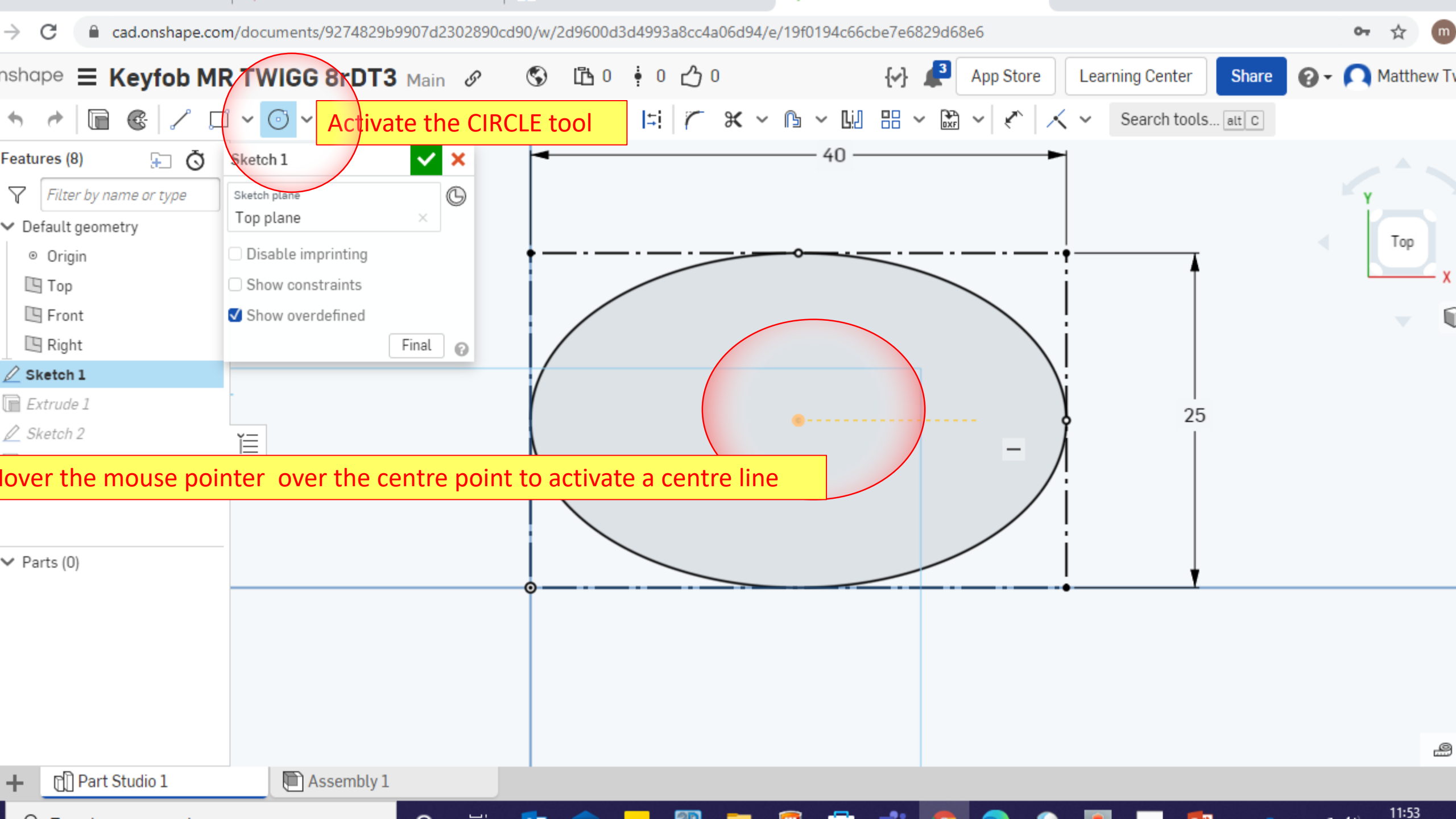

Activate the CIRCLE tool

Hover the mouse pointer over the centre point to activate a centre line



Features (8)

Filter by name or type

Default geometry

- Origin
- Top
- Front
- Right

Sketch 1

- Extrude 1
- Sketch 2
- Extrude 2

Sketch 1

Sketch plane: Top plane

Disable imprinting

Show constraints

Show overdefined

Final

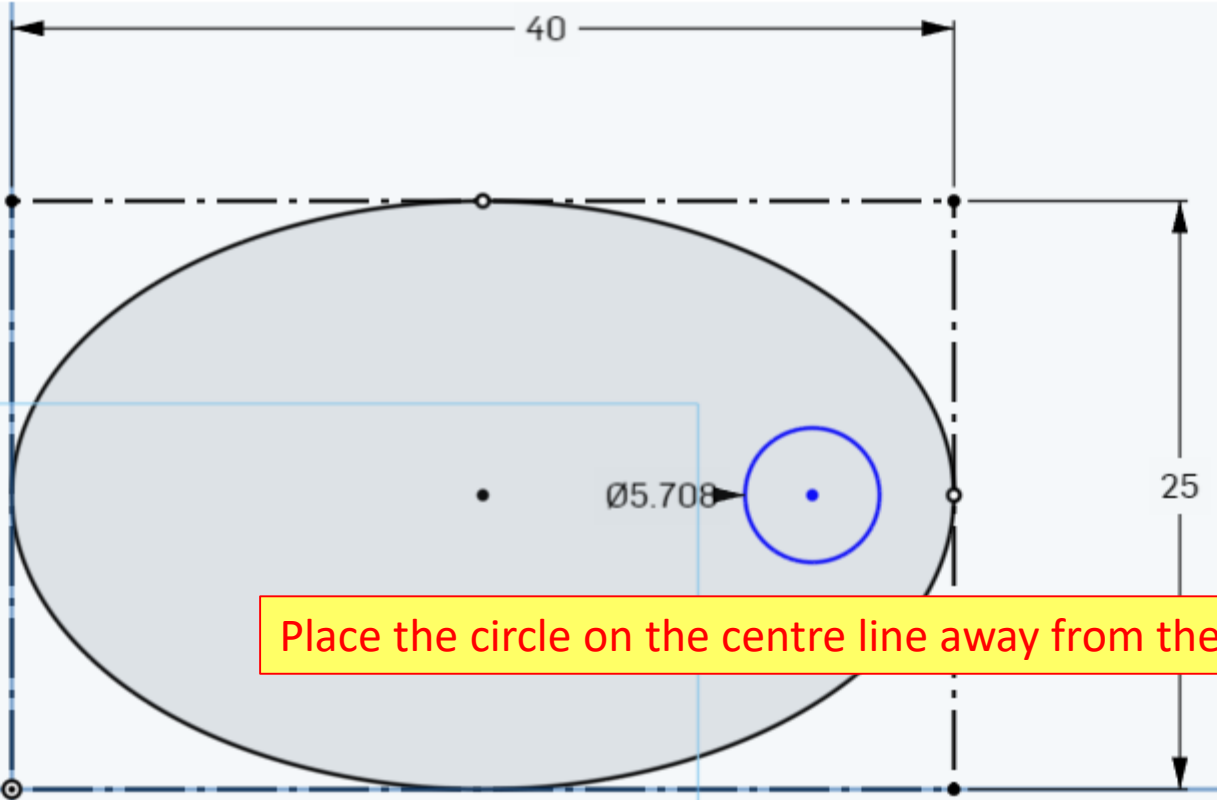

Place the circle on the centre line away from the edge



Features (8)

Filter by name or type

Default geometry

- Origin
- Top
- Front
- Right

Sketch 1

- Extrude 1
- Sketch 2
- Extrude 2

Sketch 1

Sketch plane
Top plane

Disable imprinting

Show constraints

Show overdefined

Final

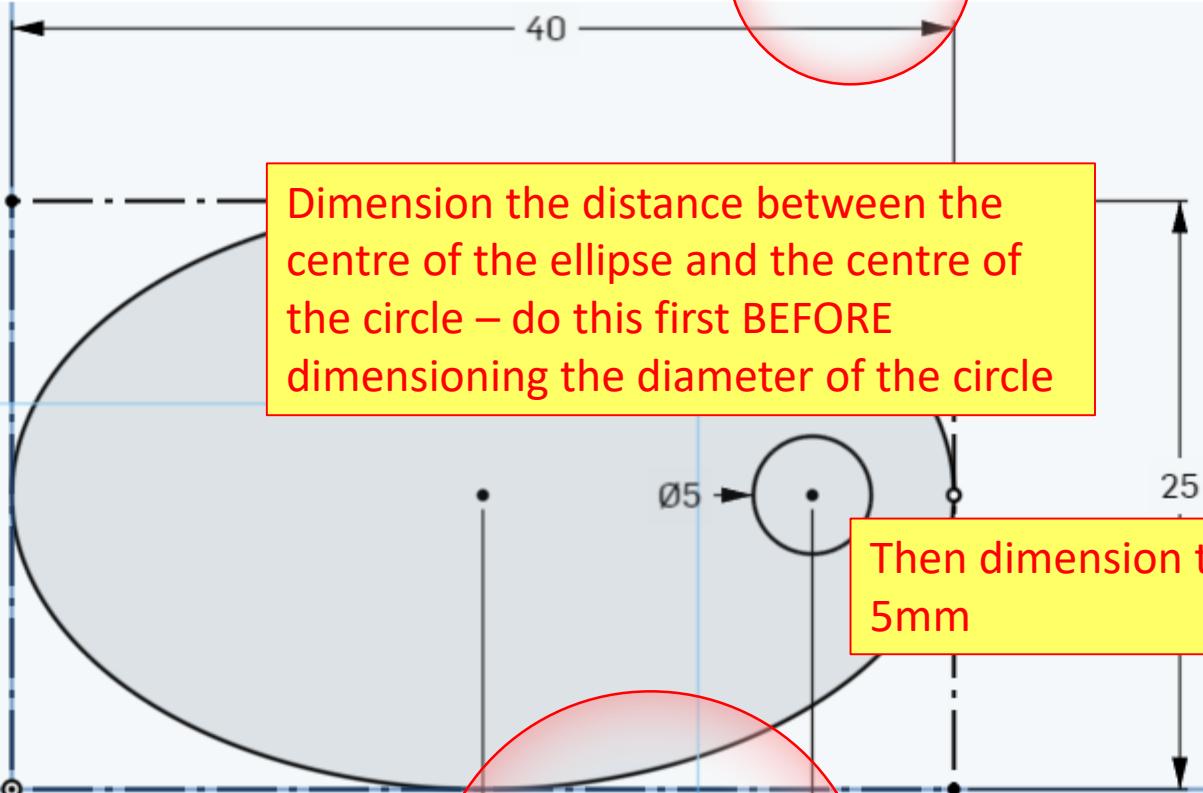

Dimension the distance between the centre of the ellipse and the centre of the circle – do this first BEFORE dimensioning the diameter of the circle

Then dimension the circle to 5mm

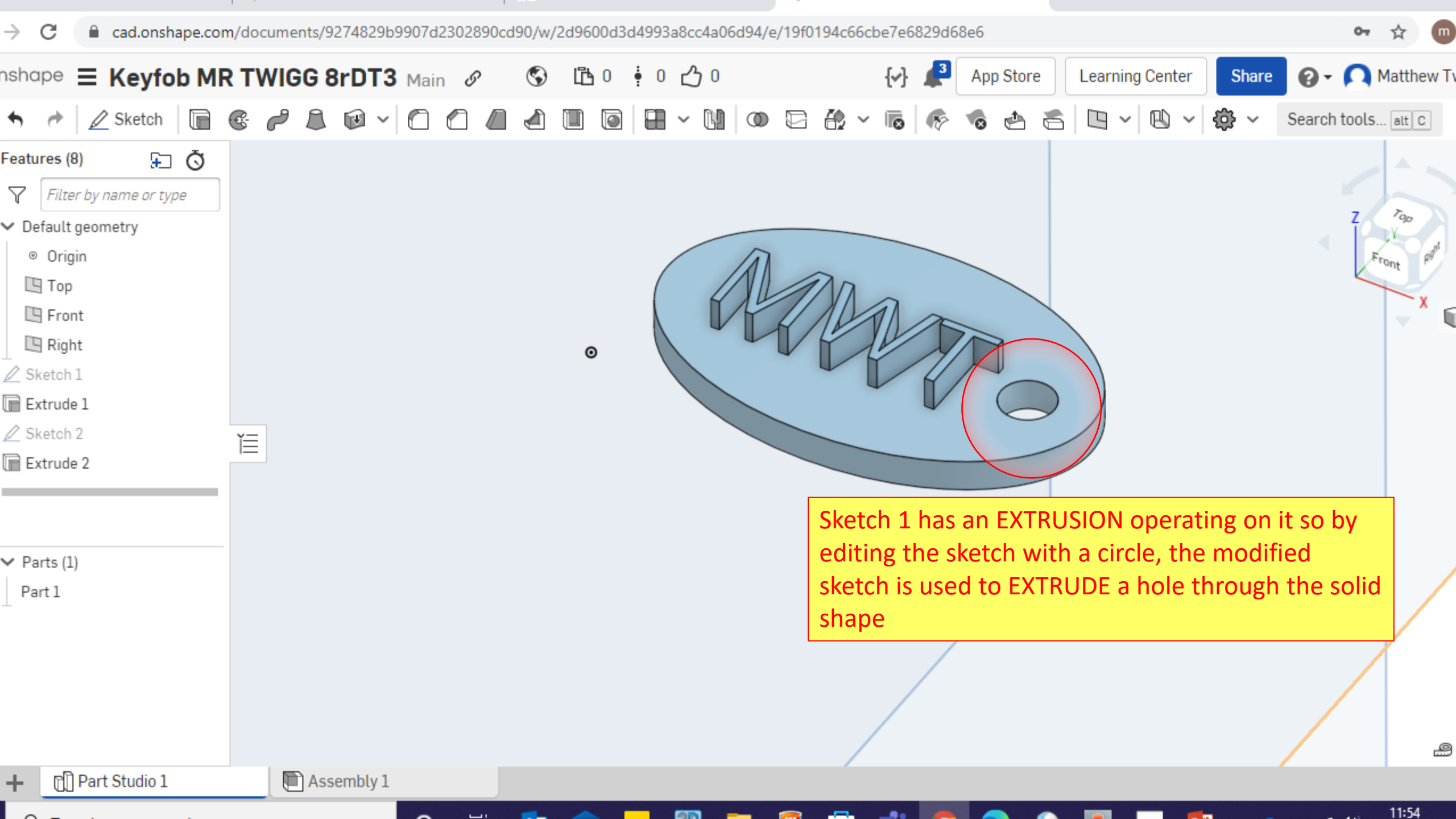

Sketch 1 has an EXTRUSION operating on it so by editing the sketch with a circle, the modified sketch is used to EXTRUDE a hole through the solid shape

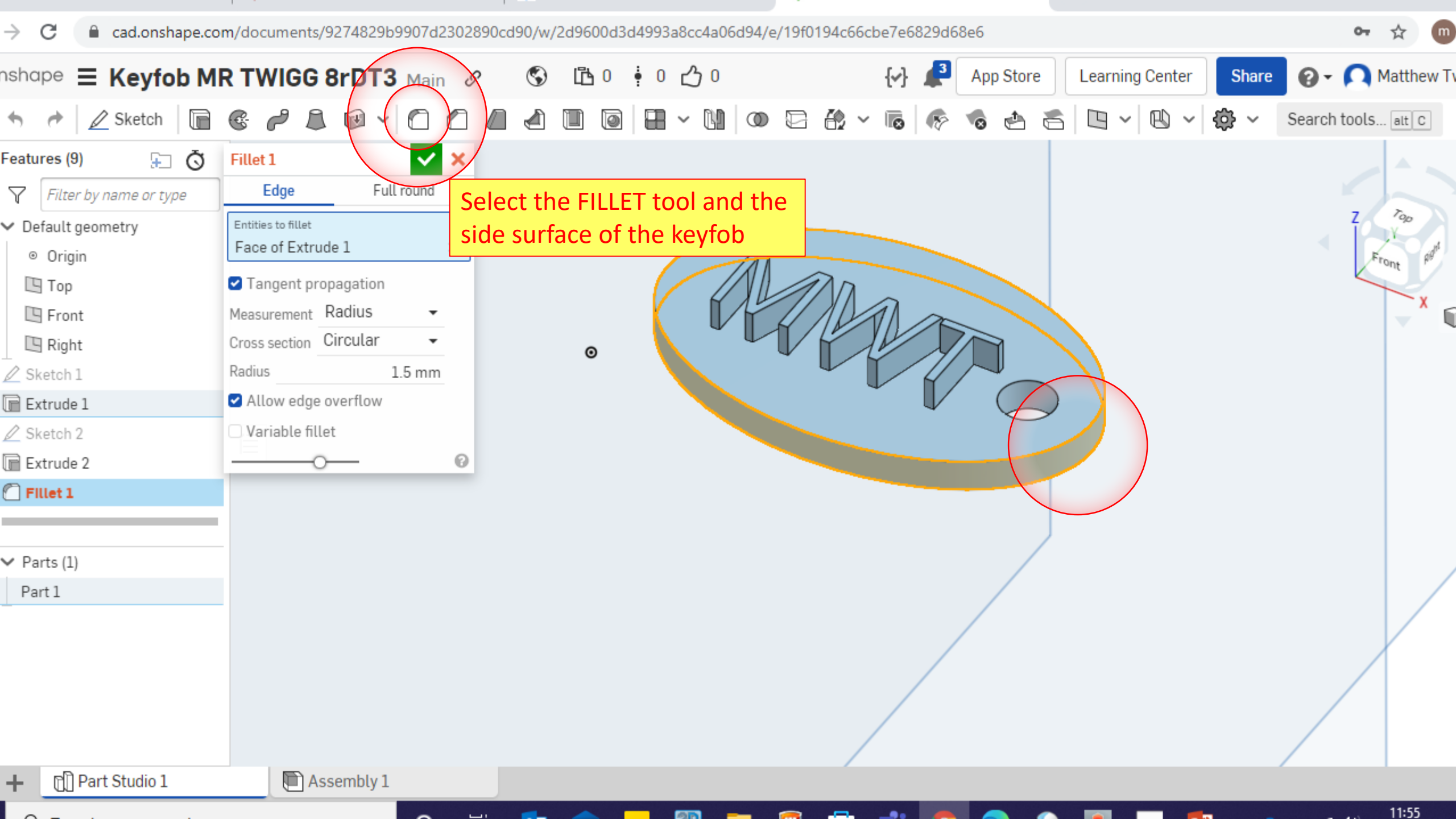

Select the FILLET tool and the side surface of the keyfob

Select the FILLET tool and the side surface of the keyfob



Features (9)

Filter by name or type

Default geometry

- Origin
- Top
- Front
- Right
- Sketch 1
- Extrude 1
- Sketch 2
- Extrude 2
- Fillet 1

Parts (1)

- Part 1

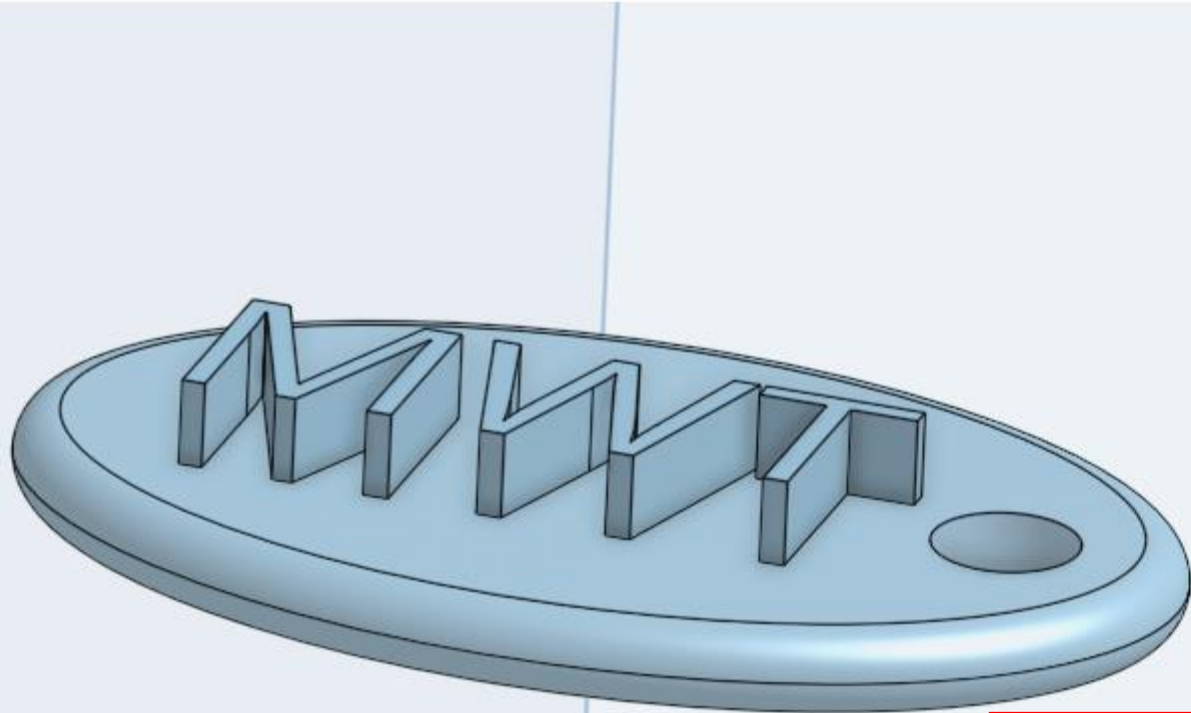

Ta-Daaa!

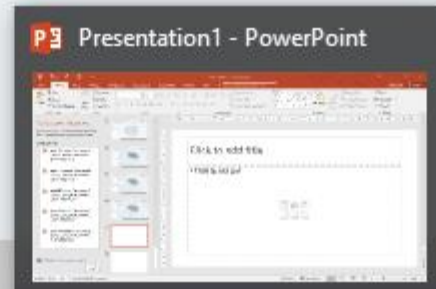

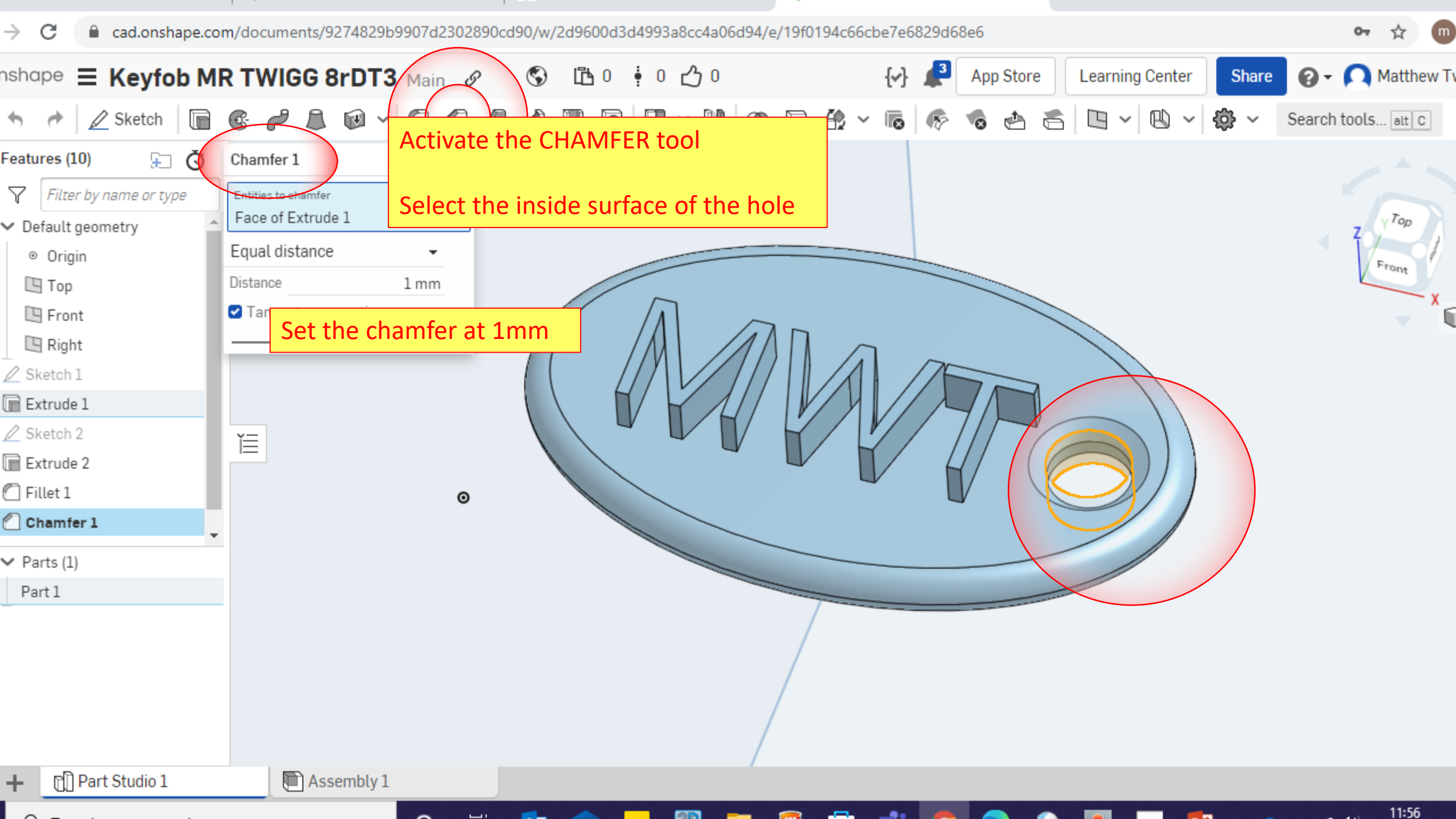

Activate the CHAMFER tool
Select the inside surface of the hole

Set the chamfer at 1mm

- Features (10)
- Filter by name or type
- Default geometry
 - Origin
 - Top
 - Front
 - Right
- Sketch 1
- Extrude 1
- Sketch 2
- Extrude 2
- Fillet 1
- Chamfer 1**
- Parts (1)
 - Part 1

Chamfer 1

Entities to chamfer

- Face of Extrude 1

Equal distance

Distance 1 mm

Tangent

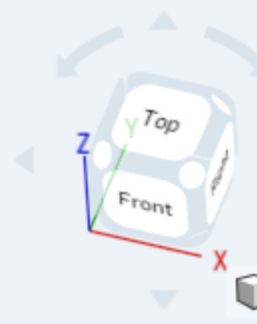
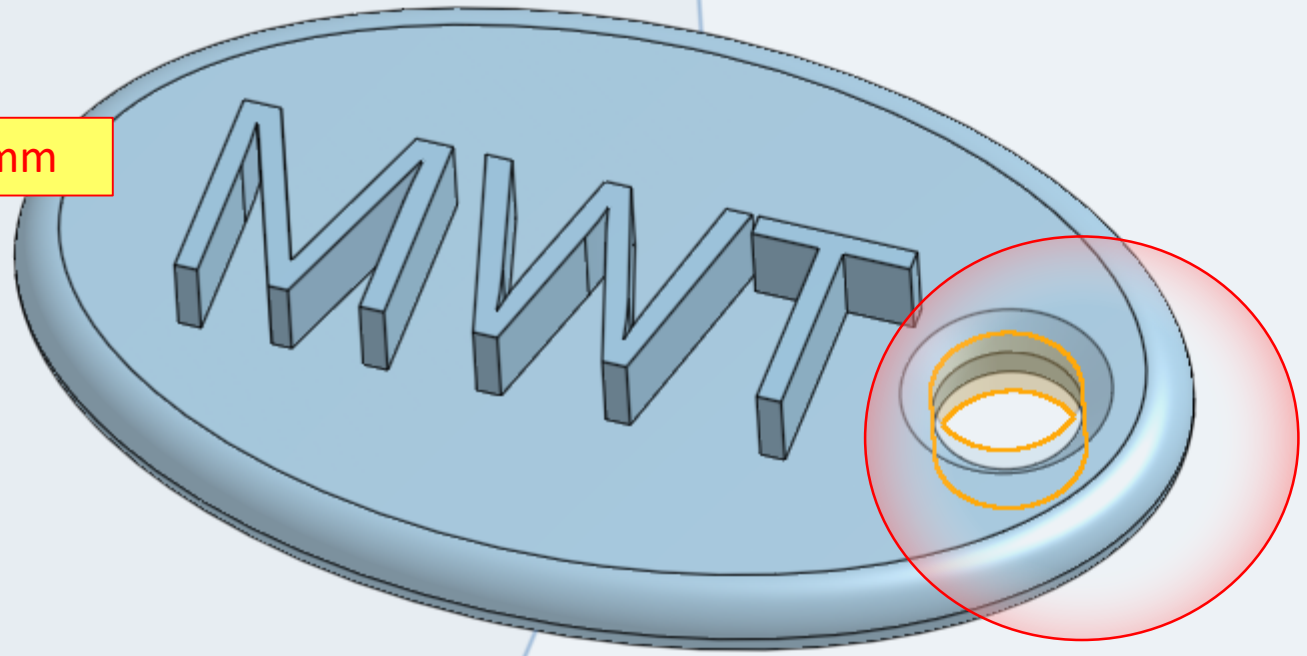

Features (10)

Filter by name or type

Default geometry

- Origin
- Top
- Front
- Right
- Sketch 1
- Extrude 1
- Sketch 2
- Extrude 2
- Fillet 1
- Chamfer 1

Parts (1)

- Part 1

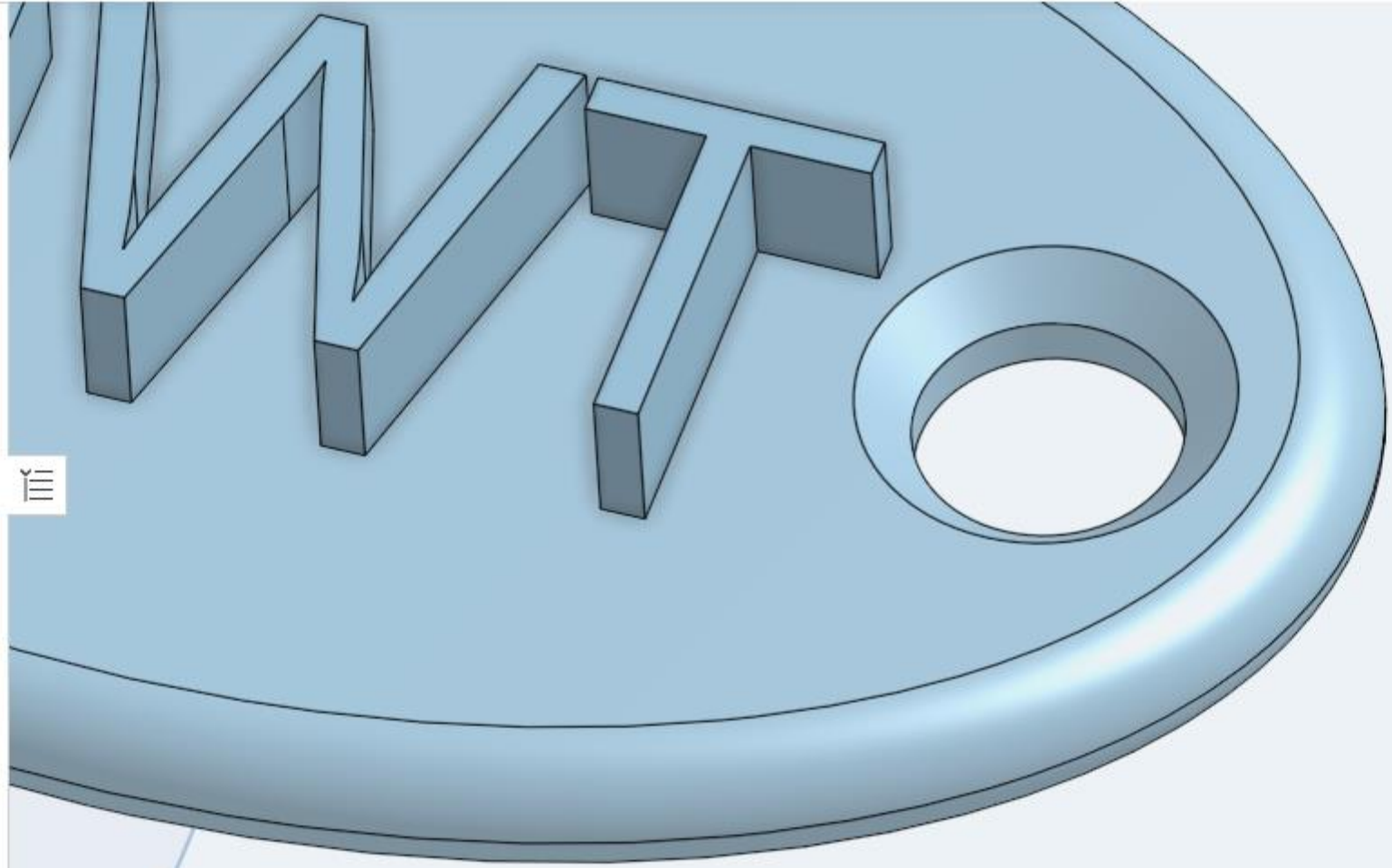

Part 2: How to Create a Series of Orthographic Technical Drawings

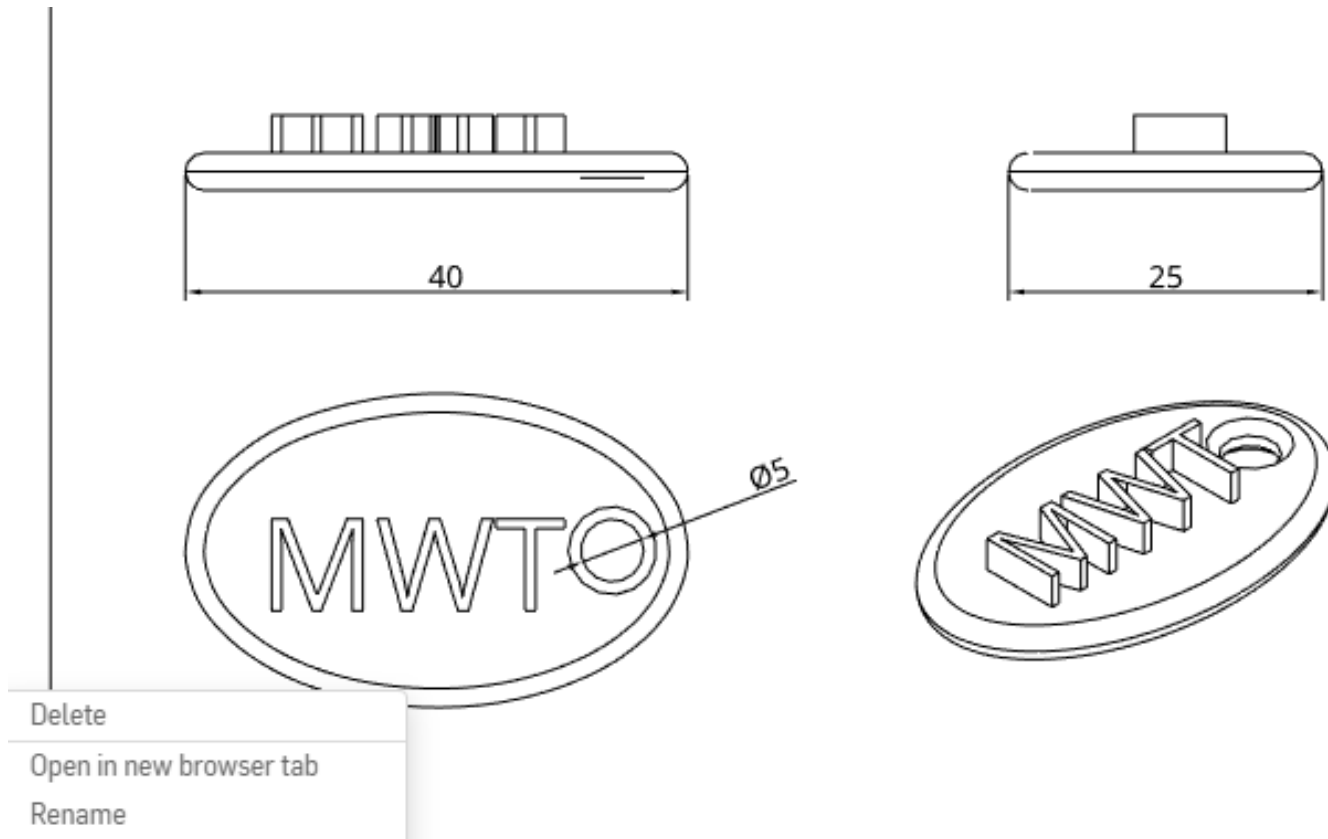

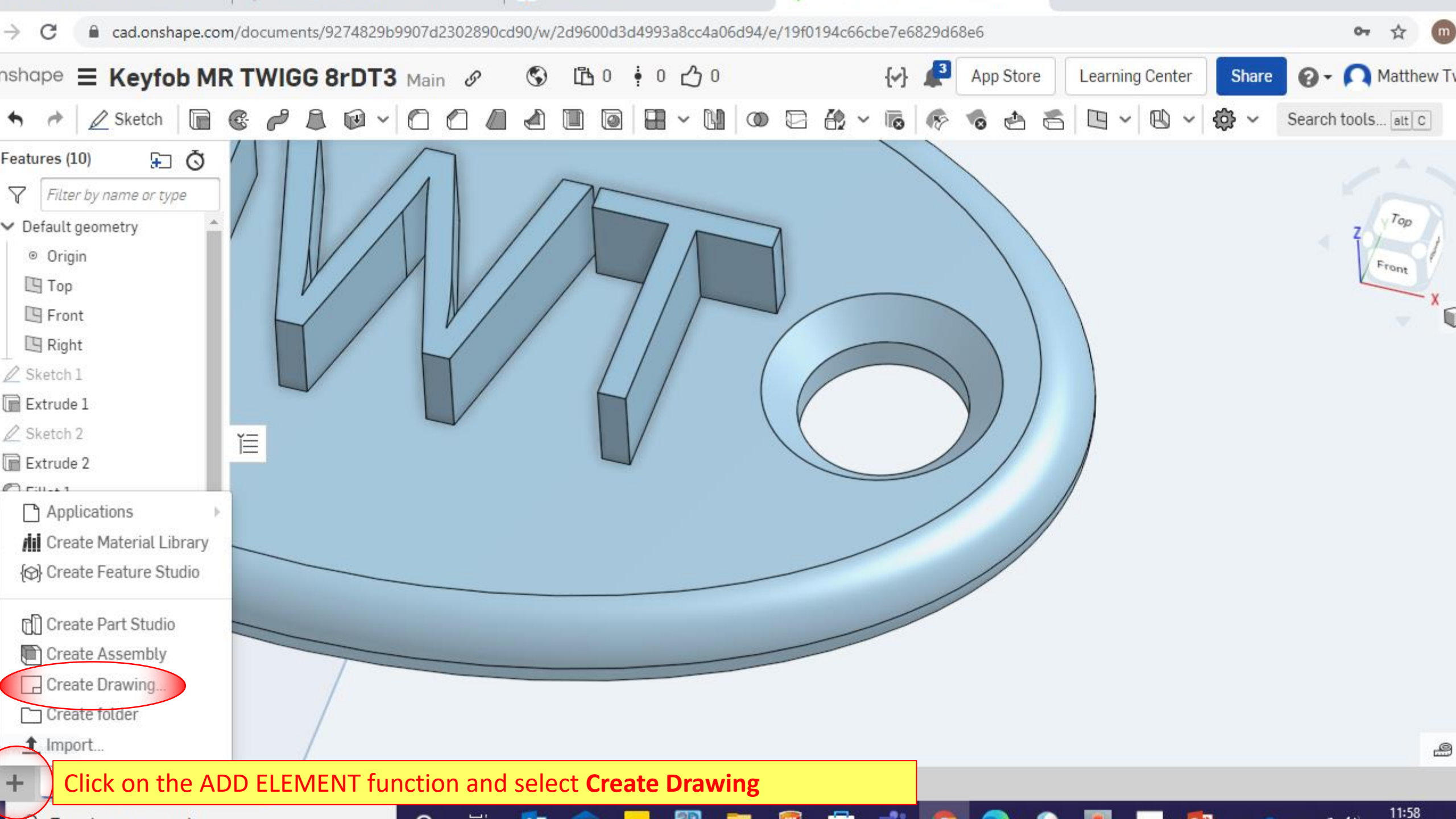

- Features (10)
- Filter by name or type
- Default geometry
 - Origin
 - Top
 - Front
 - Right
 - Sketch 1
 - Extrude 1
 - Sketch 2
 - Extrude 2
- Applications
- Create Material Library
 - Create Feature Studio
 - Create Part Studio
 - Create Assembly
 - Create Drawing...**
 - Create folder
 - Import...

+ Click on the ADD ELEMENT function and select **Create Drawing**



Create Drawing: Drawing 1

Existing templates

Custom template

- Onshape
- My Onshape
- Recently opened**
- Created by me
- Shared with me
- Public

All ANSI **ISO**

Template

Document

Owner

ISO_A3.dwt

Onshape ISO Drawing Templates

Onshape

ISO_A4.dwt

Onshape ISO Drawing Templates

Onshape

[Show Onshape drawing templates](#)

Options



OK

Cancel

The insert menu will open automatically

Insert view

- Insert
- View orientation: Front
- View scale
- View simplification: Automatic

Select a part or assembly

Current document Other documents

Keyjob MR TWIGG Main

Part Studios Assemblies

Search parts or sketches

Part Studio 1 Part 1

Part 1

Select from the CURRENT DOCUMENT – PART STUDIOS

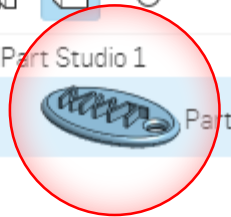

Select the Keyjob model

UNLESS OTHERWISE SPECIFIED, DIMENSIONS ARE IN MILLIMETERS	NAME	SIGNATURE	DATE	
ANGULAR ± 1°	DRAWN	MATTHEW TWIGG	09/20/2019	
SURFACE FINISH ✓	CHECKED			TITLE
DO NOT SCALE DRAWING	APPROVED			
BREAK ALL SHARP EDGES AND REMOVE BLURS				
FIRST ANGLE PROJECTION	MATERIAL	FINISH		A4
				SCALE SHEET 1 of 1



You will be given a FRONT view to start – move it to the top left hand corner and click to place it

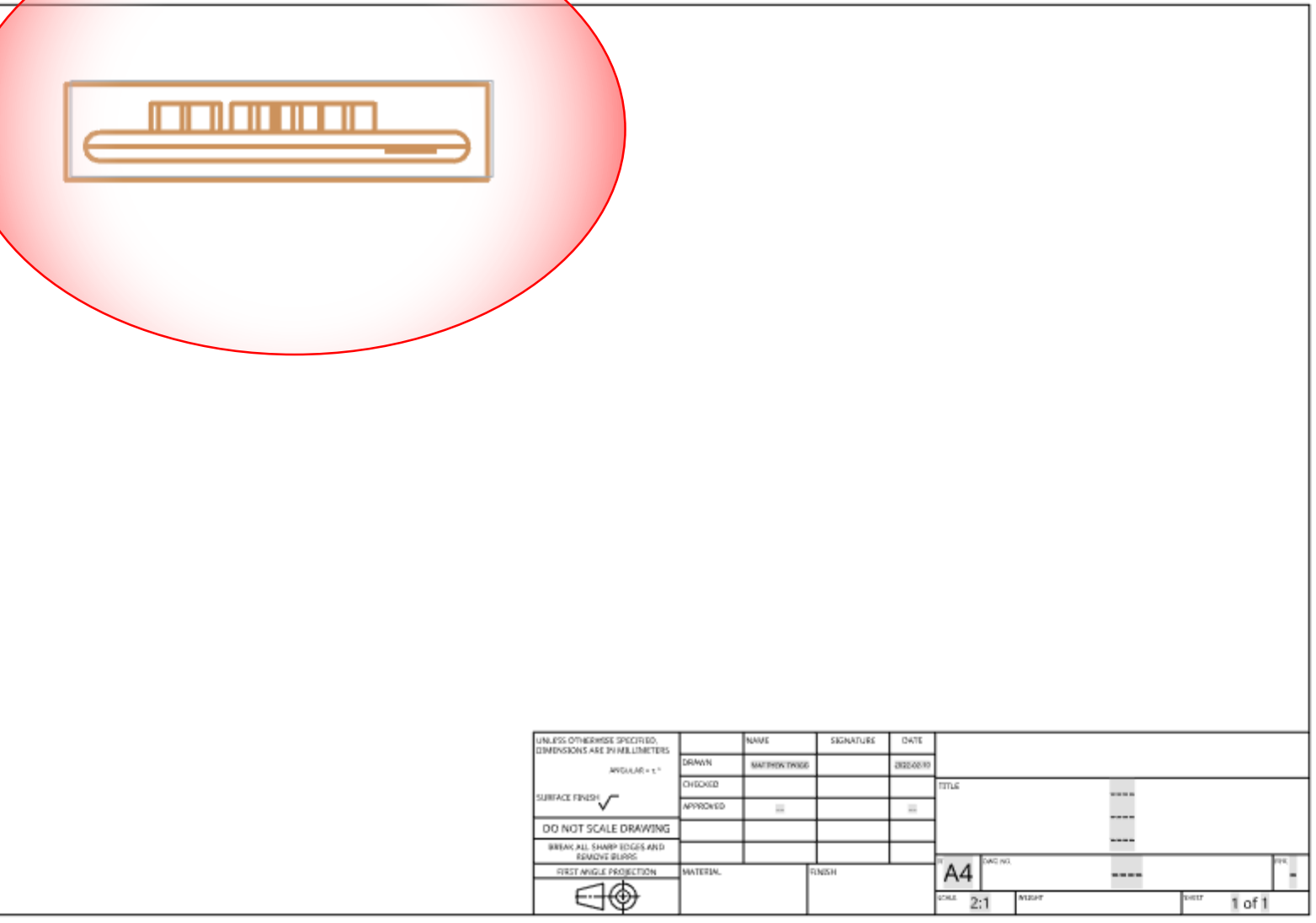

UNLESS OTHERWISE SPECIFIED, DIMENSIONS ARE IN MILLIMETERS					
ANGULAR ± 1°	DRAWN	MATHEW TWIGG		DATE	09/20/2019
SURFACE FINISH ✓	CHECKED			TITLE	
DO NOT SCALE DRAWING	APPROVED				
BREAK ALL SHARP EDGES AND REMOVE BLURS	MATERIAL		FINISH		A4
FIRST ANGLE PROJECTION					SCALE 2:1
				SHEET 1 of 1	



Sheet1

The front view will turn orange brown – move the mouse down below the front view and click to place the top view

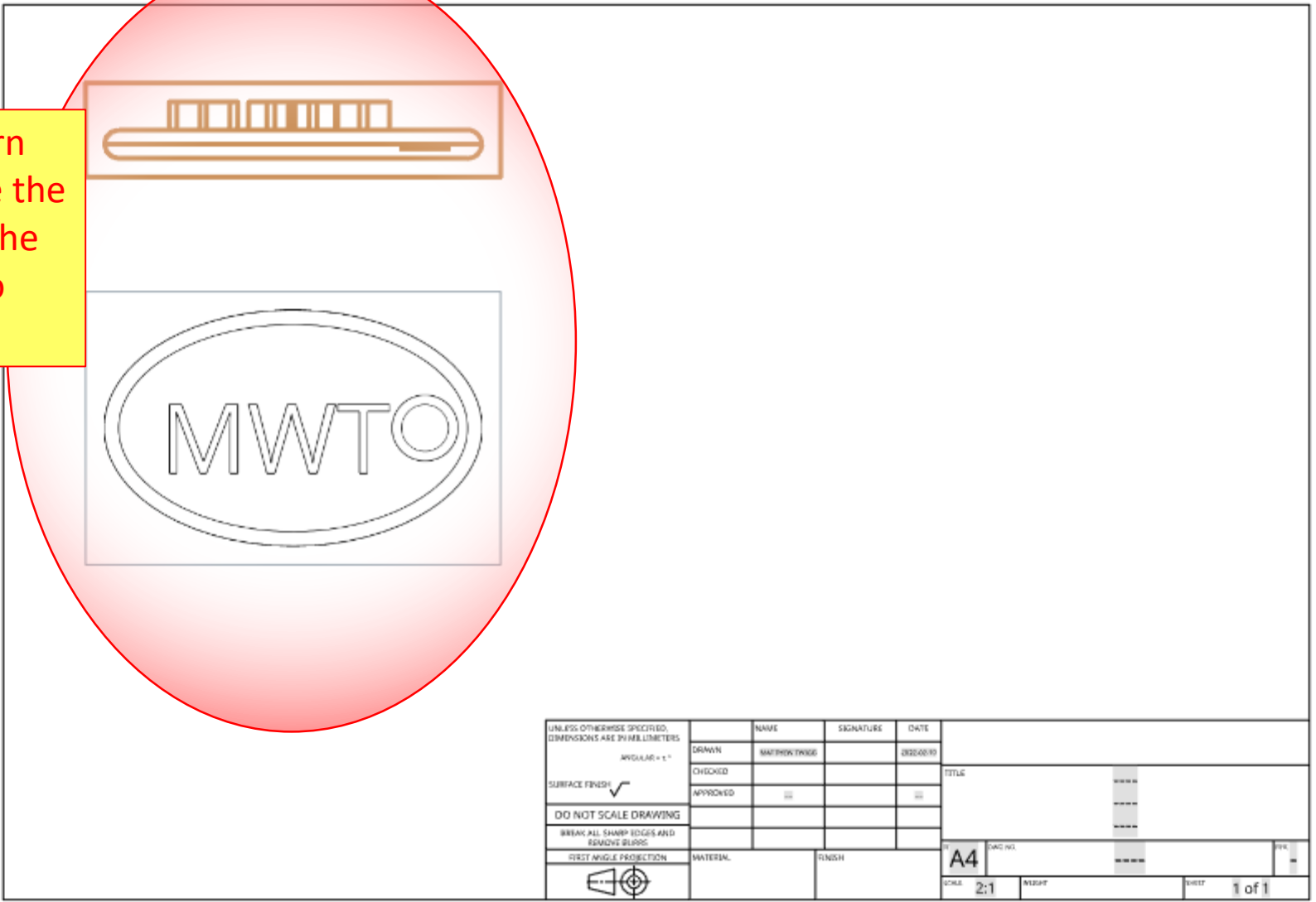

UNLESS OTHERWISE SPECIFIED, DIMENSIONS ARE IN MILLIMETERS					
ANGULAR ± 1°	DRAWN	NAME	SIGNATURE	DATE	
		MATHEW TWIGG		09/20/20	
SURFACE FINISH ✓	CHECKED				TITLE
	APPROVED				
DO NOT SCALE DRAWING					
BREAK ALL SHARP EDGES AND REMOVE BLURS					
FIRST ANGLE PROJECTION	MATERIAL		FINISH		A4
					SCALE 2:1
					SHEET 1 of 1



Sheet1

Re-select the front view to turn it orange brown orange brown – move the mouse to the right to place the side view ...



UNLESS OTHERWISE SPECIFIED, DIMENSIONS ARE IN MILLIMETERS				NAME	SIGNATURE	DATE	
ANGULAR ± 1°	DRAWN	MATHEW TWIGG		09/20/2019			
SURFACE FINISH ✓	CHECKED				TITLE		
DO NOT SCALE DRAWING	APPROVED						
BREAK ALL SHARP EDGES AND REMOVE BLURS							
FIRST ANGLE PROJECTION	MATERIAL		FINISH		A4		
					SCALE 2:1	SHEET 1 of 1	

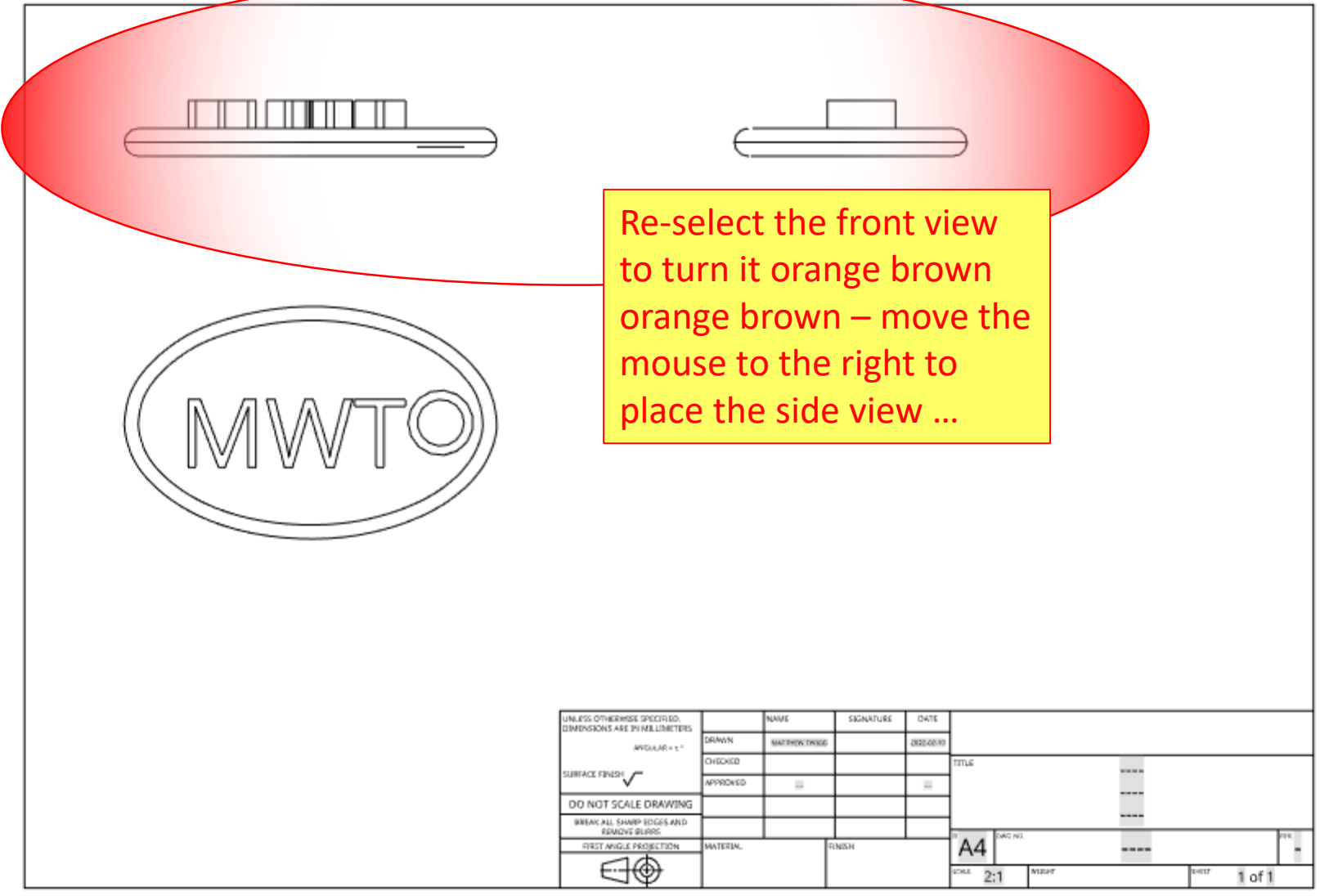
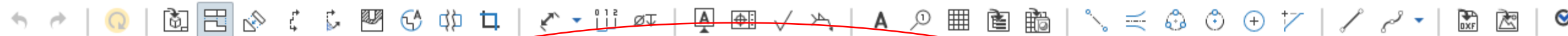

UNLESS OTHERWISE SPECIFIED, DIMENSIONS ARE IN MILLIMETERS				NAME	SIGNATURE	DATE	
ANGULAR ± 1°	DRAWN	MATHEW TWIGG		09/20/2019			
SURFACE FINISH ✓	CHECKED				TITLE		
DO NOT SCALE DRAWING	APPROVED						
BREAK ALL SHARP EDGES AND REMOVE BLURS							
FIRST ANGLE PROJECTION	MATERIAL		FINISH		A4		
					SCALE 2:1	SHEET 1 of 1	



Sheet1

Re-select the front view to turn it orange brown orange brown – move the mouse to the diagonally down and right to place the ISOMETRIC view ...

UNLESS OTHERWISE SPECIFIED, DIMENSIONS ARE IN MILLIMETERS

ANGULAR ± 1°

SURFACE FINISH ✓

DO NOT SCALE DRAWING

BREAK ALL SHARP EDGES AND REMOVE BURRS

FIRST ANGLE PROJECTION

	NAME	SIGNATURE	DATE
DRAWN	MATTHEW TWIGG		20220830
CHECKED			
APPROVED			

TITLE	

SCALE	SHEET	TOTAL SHEETS
2:1		1 of 1



Sheet1

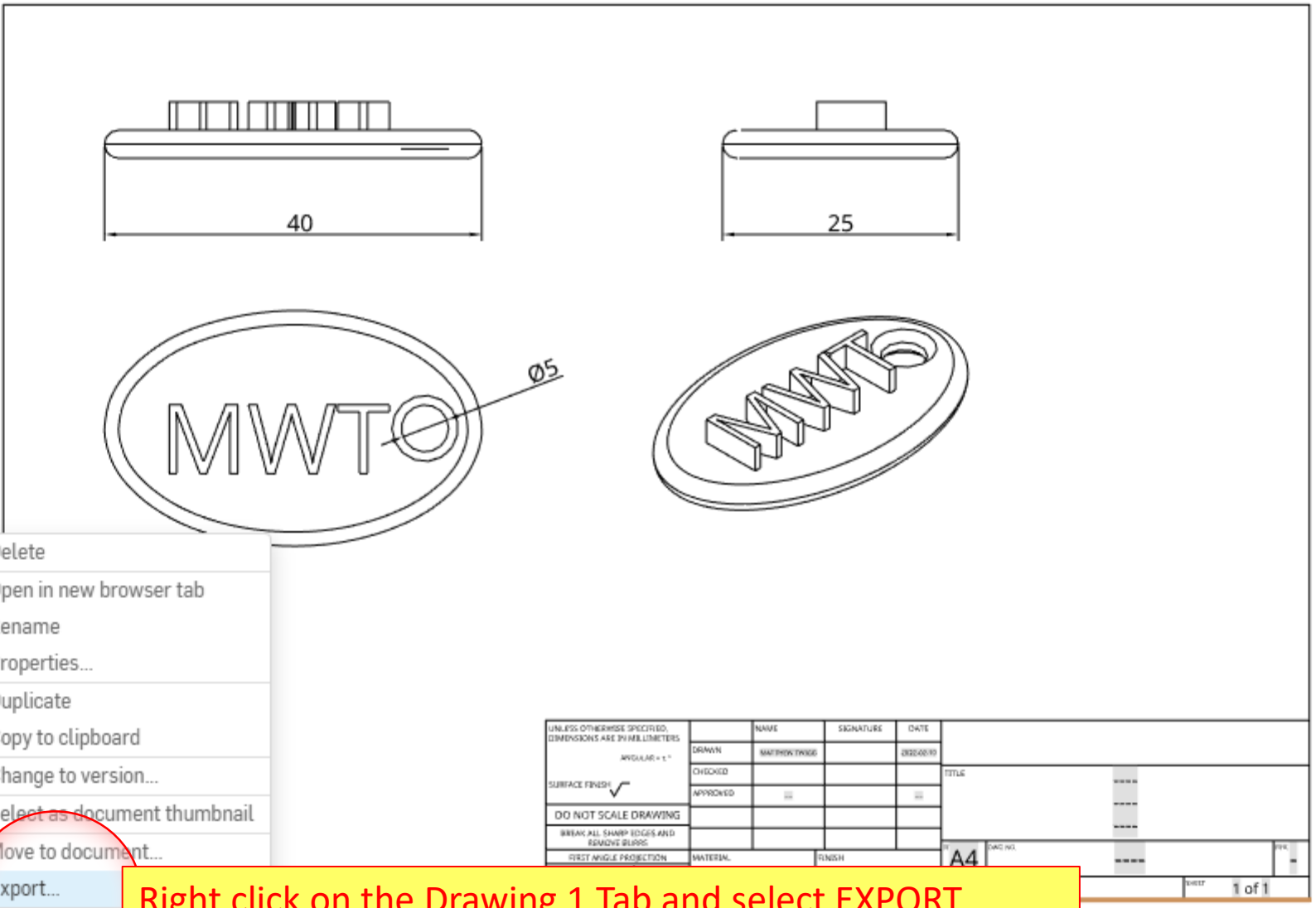

- Delete
- Open in new browser tab
- Rename
- Properties...
- Duplicate
- Copy to clipboard
- Change to version...
- Select as document thumbnail
- Move to document...
- Export...**
- Drawing 1

Right click on the Drawing 1 Tab and select EXPORT

Export drawing

File name: Drawing 1

Format: PDF

Overridden dimensions: Show underlines

Text: Normal

Color: Color

Options: Download

Export Cancel

Export as a PDF file

UNLESS OTHERWISE SPECIFIED, DIMENSIONS ARE IN MILLIMETERS			
ANGULAR ± 1°	NAME	SIGNATURE	DATE
DRAWN	MATTHEW TWIGG		08/20/20
CHECKED			
APPROVED			
DO NOT SCALE DRAWING	TITLE		
BREAK ALL SHARP EDGES AND REMOVE BURRS			
FIRST ANGLE PROJECTION	MATERIAL	FINISH	A4
			SCALE 2:1 SHEET 1 of 1



When it opens in your PDF reader – PRINT your awesome drawing out!!!

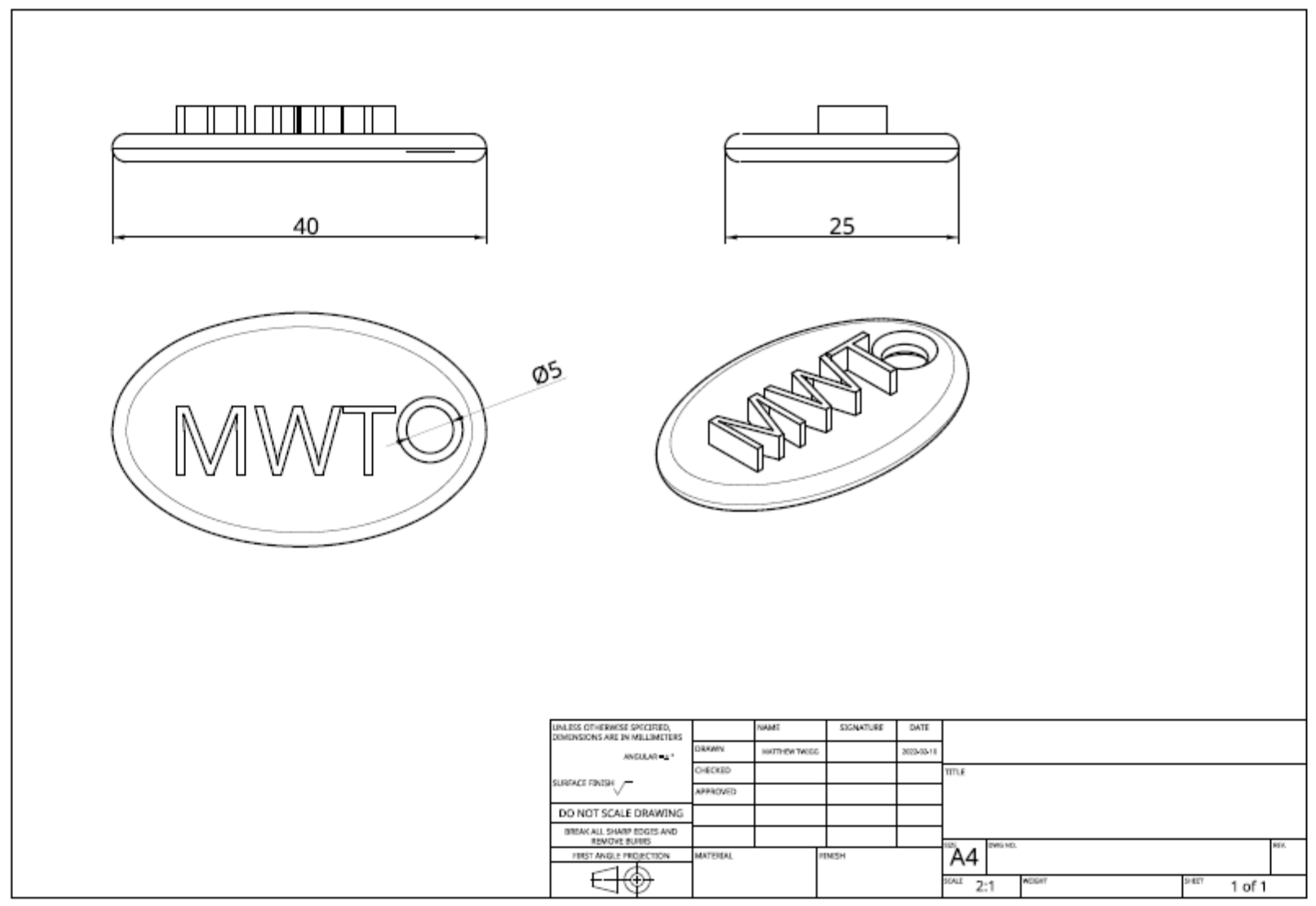

Search 'Delete Page'

- Export PDF
- Edit PDF
- Create PDF
- Comment
- Combine Files
- Organize Pages
- Compress PDF
- Redact
- Protect
- Adobe Sign
- Fill & Sign
- Send for Comme...

Part 3: How to Export an STL file for 3D Printing

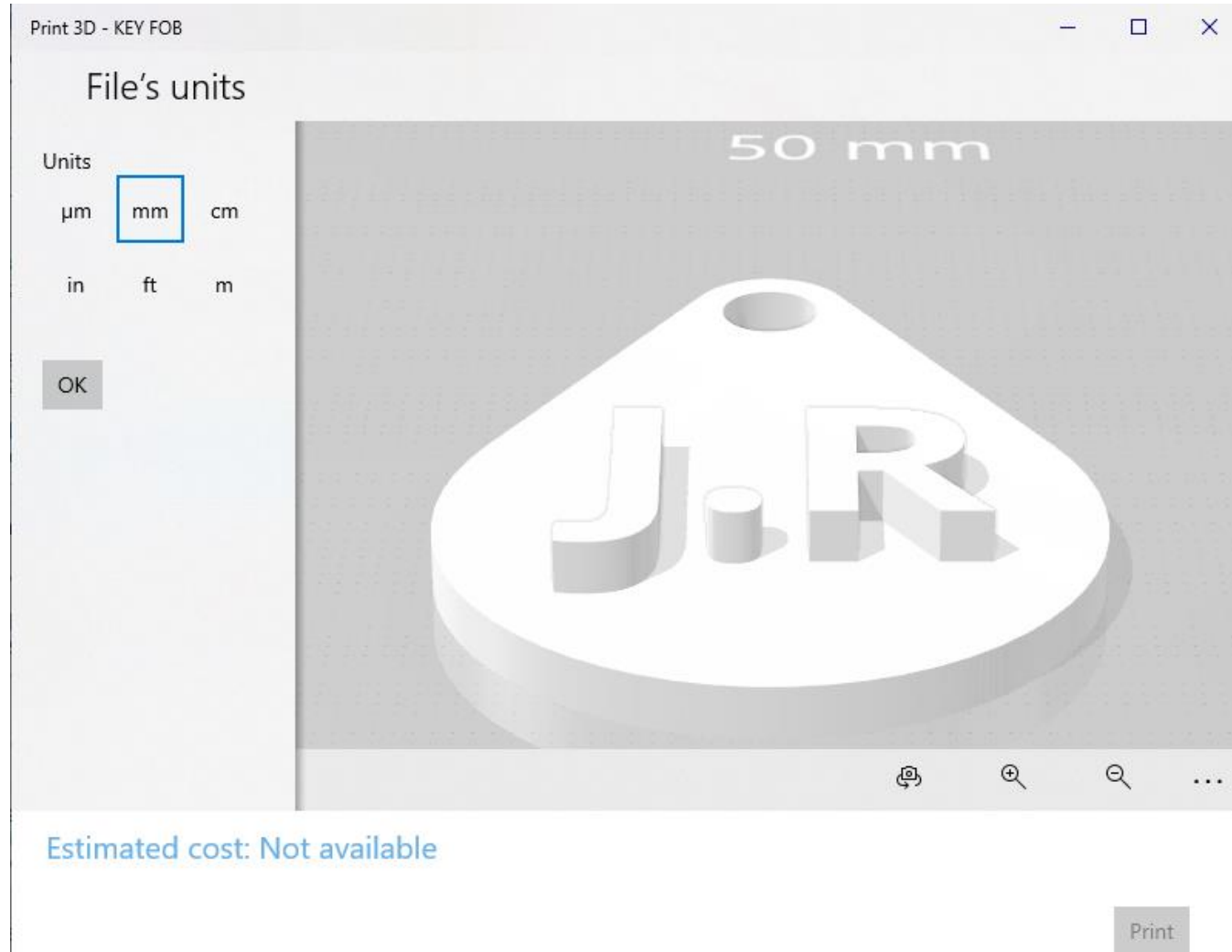



Features (10)

Filter by name or type

Default geometry

- Origin
- Top
- Front
- Right

- Sketch 1
- Extrude 1
- Sketch 2
- Extrude 2
- Fillet 1

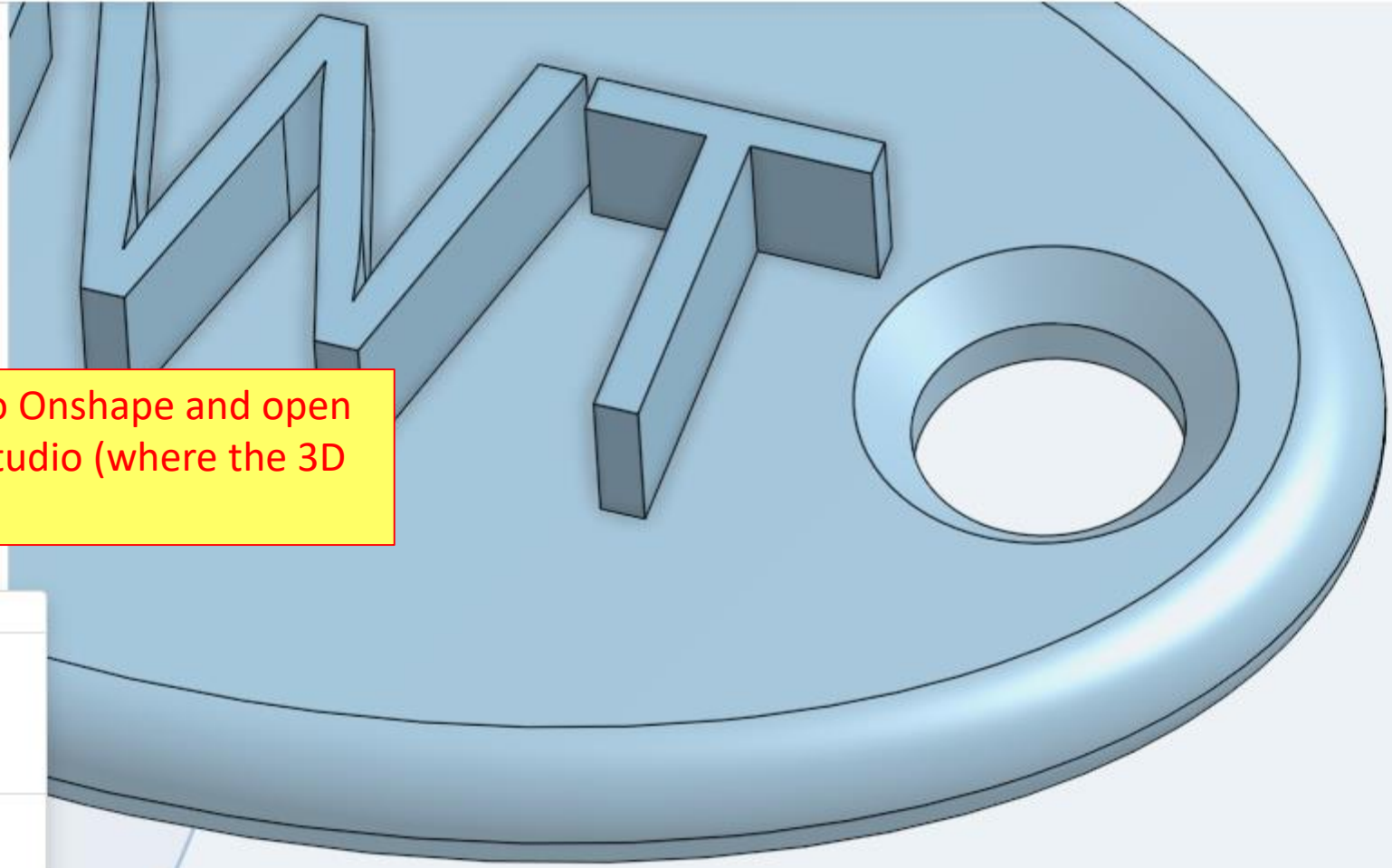

Go back to Onshape and open the Part Studio (where the 3D model is)

- Delete
- Open in new browser tab
- Rename
- Properties...
- Show code
- Duplicate
- Copy to clipboard
- Select as document thumbnail
- Move to document...
- Export...
- Part Studio 1

Right click on the Part Studio Tab - Select EXPORT

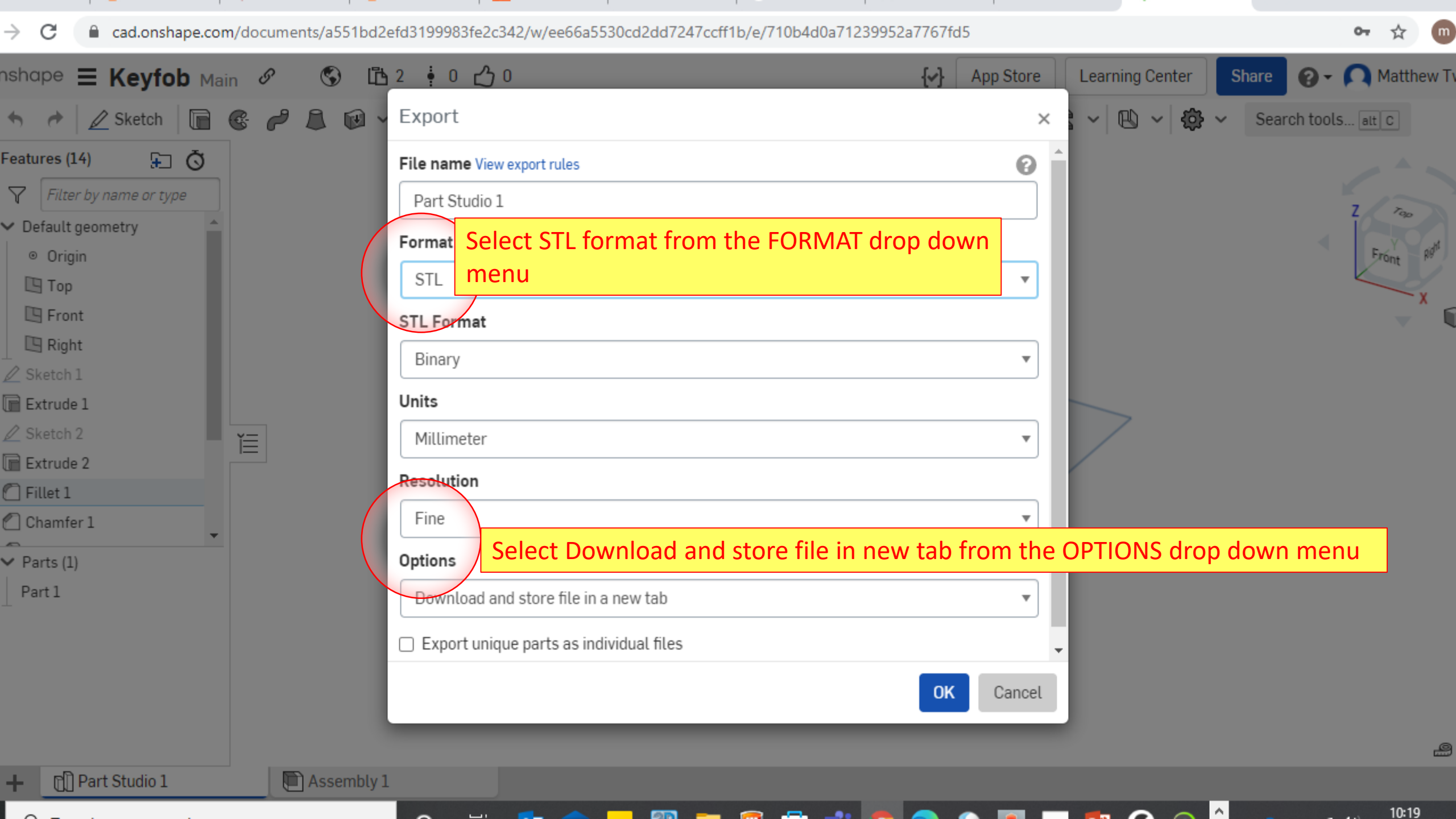

Export

File name [View export rules](#) ?

Part Studio 1

Format **Select STL format from the FORMAT drop down menu**

STL

STL Format

Binary

Units

Millimeter

Resolution

Fine

Options **Select Download and store file in new tab from the OPTIONS drop down menu**

Download and store file in a new tab

Export unique parts as individual files

OK Cancel



Part Studio 1.stl

STL file

File size: 1 MB

Uploaded 12:04 pm Feb 10

Update...

Download

Select **DOWNLOAD** – and save it to a folder in your drive (Create one called STL files)

A new tab will be created: Part Studio STL – open it!

You may now use a Slicing programme to prepare it for 3D printing....

Part Studio 1

Part Studio 1.stl

Drawing 1

Assembly 1

Part Studio 1 (7).stl

Show all

You may now use a slicing programme to prepare it for 3D printing for example the Prusa Slicer



Delete [Del]

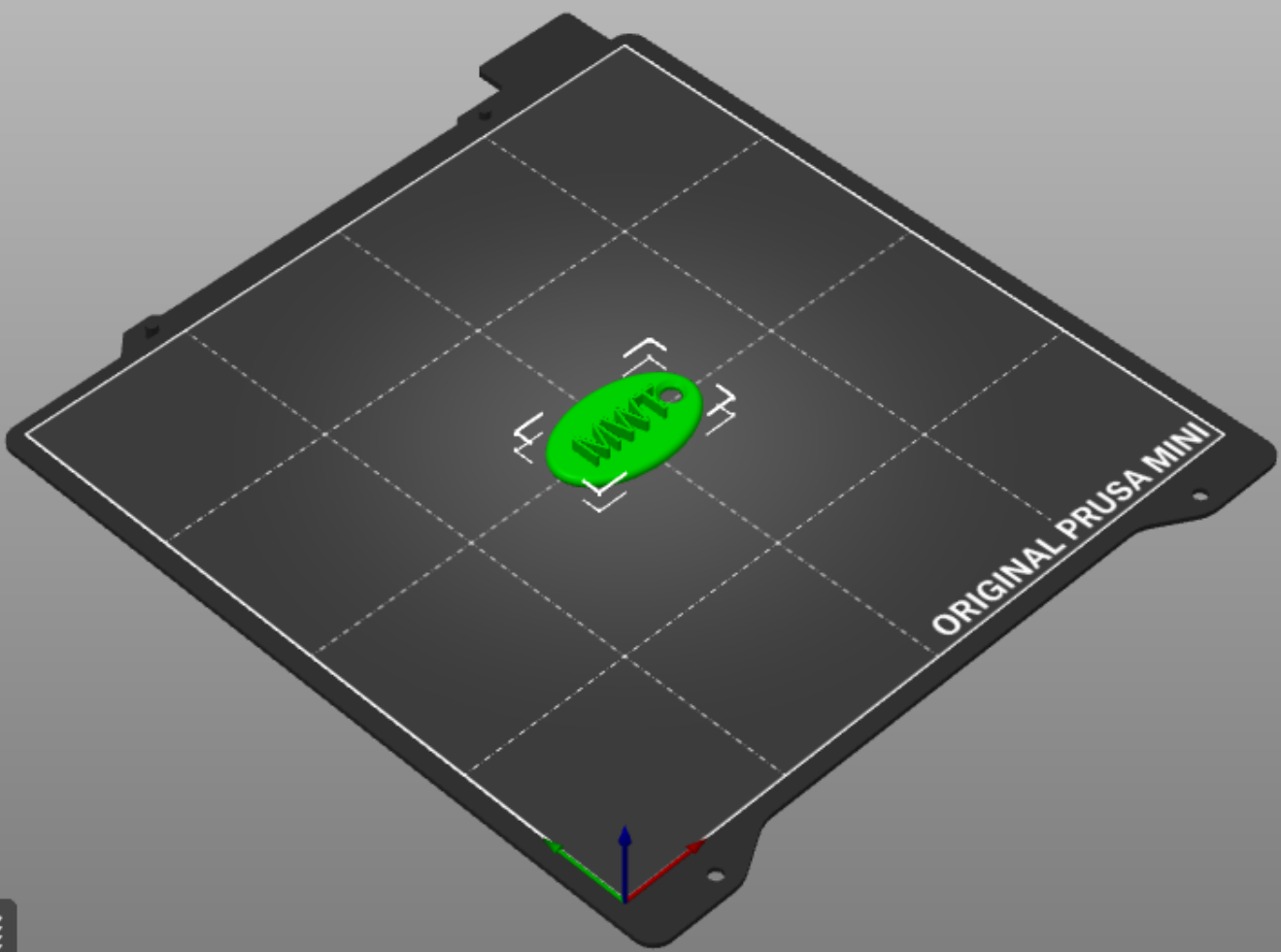

Print settings : 0.15mm QUALITY

Filament : Prusament PLA

Printer : Original Prusa MINI & MINI+

Supports: None

Infill: 15% Brim:

Name	Editing
Part Studio 1 (8).stl	<input type="checkbox"/>

Object manipulation

World coordinates

	X	Y	Z	
Position:	90	90	3	mm
Rotate:	0	0	0	°
Scale factors:	100	100	100	%
Size:	40	25	6	mm

Inches

Slice now